

FLUE GAS OUTLET CONNECTION		
FLANGE DIMENSIONS	in	mm
O.D.	25.00	635
I.D.	20.25	514
B.C.D	22.50	572
HOLE DIAMETER	0.53	13
No. OF HOLES	8	

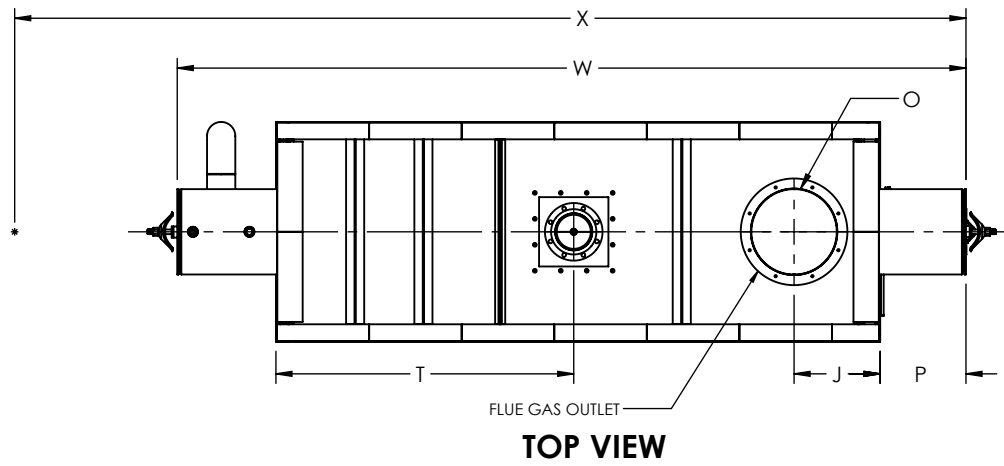

GENERAL DIMENSIONS		
	in	mm
A	BOILER BASE LENGTH	141.63 3597
B	BOILER HOUSING HEIGHT	102.85 2612
C	BOILER BASE WIDTH	51.50 1308
D	CENTER OF BOTTOM DRUM TO CENTER OF TOP DRUM	75.00 1905
E	CENTER OF BOTTOM DRUM TO BOTTOM	12.81 325
F	CENTER OF BURNER OPENING TO BOTTOM	38.31 973
G	STEAM OUTLET, FLANGE, CLASS 150 (NPS)	8.00 203
H	TOP DRUM CLEARANCE FROM FRONT	23.24 590
J	CENTER OF FLUE GAS OUTLET TO REAR	20.08 510
K	BOTTOM DRUM CLEARANCE FROM FRONT	18.94 481
L	TUBE REMOVAL CLEARANCE FROM BASE	35.00 889
M	UPPER DRUM, O.D.	20.00 508
N	LOWER DRUM, O.D.	10.75 273
O	FLUE GAS OUTLET, I.D.	20.00 508
P	TOP DRUM CLEARANCE FROM REAR	20.22 514
Q	BOTTOM BLOWDOWN (NPT)	1.50 38
R	BURNER LENGTH	0.00
S	CENTER OF TOP DRUM TO TOP OF STEAM OUTLET	16.50 419
T	CENTER OF STEAM OUTLET TO FRONT	69.69 1770
U	FEEDWATER INLET, COUPLING (NPT)	2.00 51
V	FEEDWATER ELEVATION FROM BOTTOM	57.81 1468
W	OVERALL BOILER LENGTH	184.86 4695
X	OVERALL BOILER LENGTH WITH BURNER	0.00
Y	OVERALL BOILER HEIGHT	104.31 2649

NOTE: DIMENSIONS SUBJECT TO CHANGE WITHOUT NOTICE. CONSULT FACTORY FOR CERTIFIED DIMENSIONS.

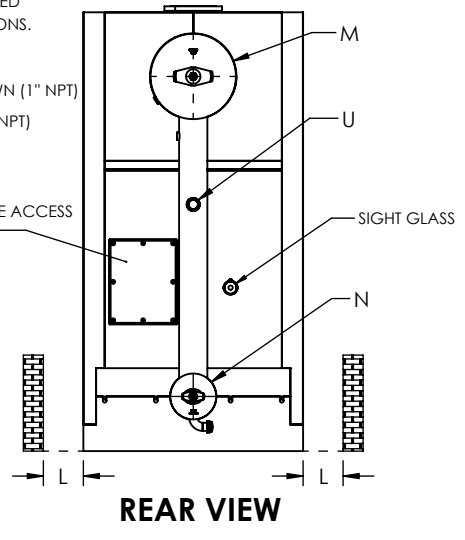
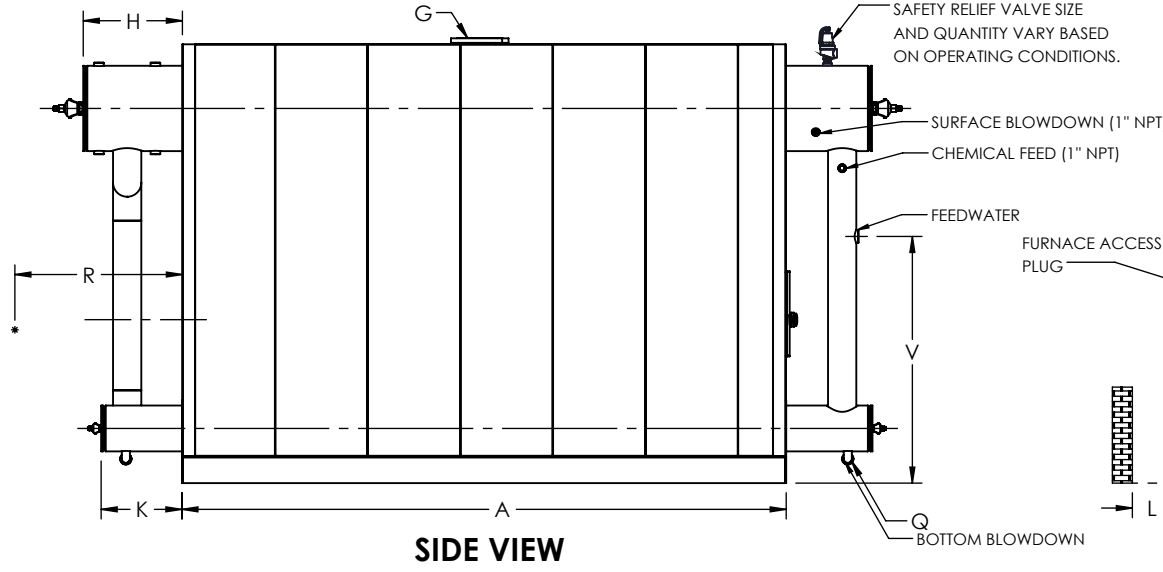
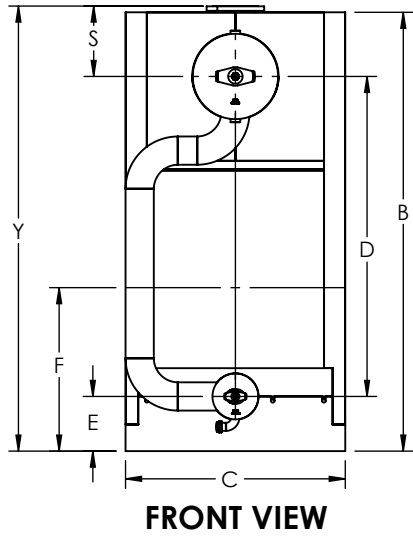

UNILUX ADVANCED MFG., LLC.
 30 COMMERCE PARK DRIVE
 NISKAYUNA, NY 12309
 Ph: (518) 344-7490

THIS DRAWING EMBODIES A CONFIDENTIAL PROPRIETARY DESIGN. ALL RIGHTS FOR REPRODUCTION, MANUFACTURING OR PATENTS ARE RESERVED BY UNILUX ADVANCED MANUFACTURING, LLC.

Drawn By: -	Date: -
Checked By: -	Date: -
Drawing No. : ZF 1000LS-SUBMITTAL	
File No. : QBXXX	REV. : 00

PROJECT:	-
LOCATION:	-
MODEL:	ZF 1000LS
BURNER:	-
ELECTRIC:	-
SUPPLY PSI:	-

ZONE	REV.	DESCRIPTION	DATE
REVISIONS			