

FLUE GAS OUTLET CONNECTION		
FLANGE DIMENSIONS	in	mm
O.D.	13.00	330
I.D.	8.25	210
B.C.D	10.50	267
HOLE DIAMETER	0.53	13
No. OF HOLES	6	

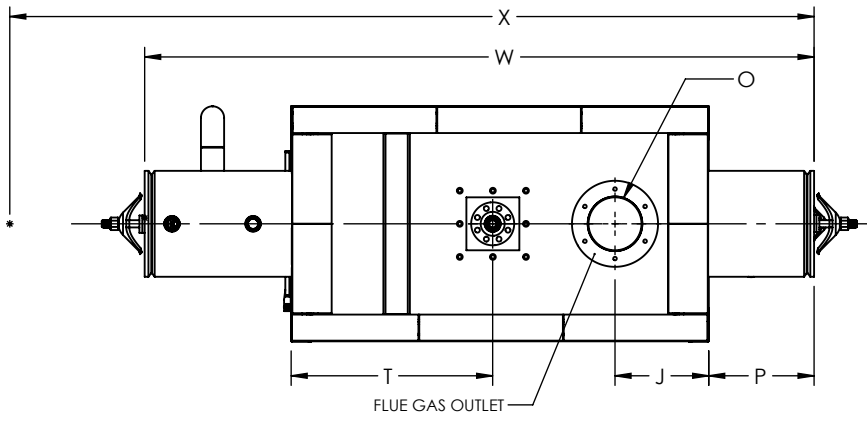

TOP VIEW

GENERAL DIMENSIONS		
	in	mm
A	62.97	1600
B	76.66	1947
C	35.50	902
D	54.00	1372
E	9.50	241
F	25.88	657
G	2.00	51
H	22.17	563
J	14.15	359
K	16.50	419
L	19.00	483
M	16.00	406
N	8.63	219
O	8.00	203
P	15.92	404
Q	1.50	38
R	0.00	0.00
S	14.50	368
T	30.39	772
U	1.00	25
V	41.50	1054
W	101.11	2568
X	0.00	0.00
Y	78.00	1981

NOTE: DIMENSIONS SUBJECT TO CHANGE WITHOUT NOTICE. CONSULT FACTORY FOR CERTIFIED DIMENSIONS.

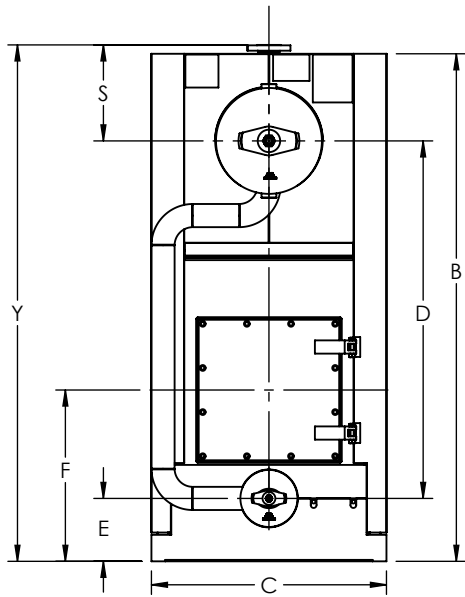

FRONT VIEW

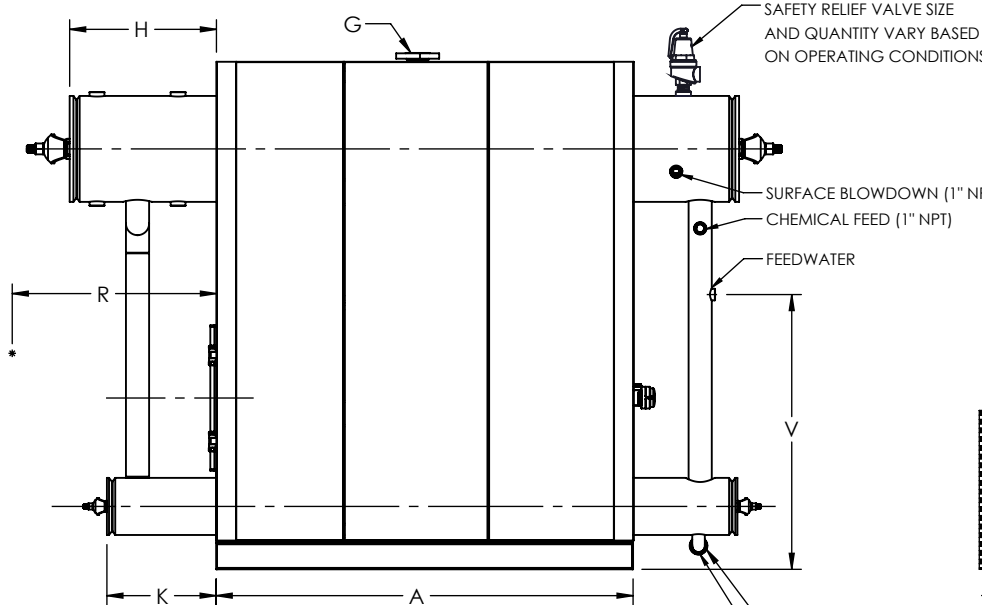

SIDE VIEW

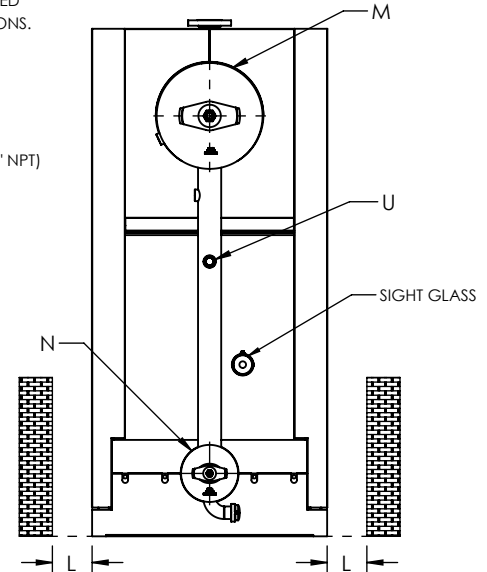

REAR VIEW

ZONE	REV.	DESCRIPTION	DATE
REVISIONS			

PROJECT:	-
LOCATION:	-
MODEL:	ZF 150HS
BURNER:	-
ELECTRIC:	-
SUPPLY PSI:	-

UNILUX ADVANCED MFG., LLC.
 30 COMMERCE PARK DRIVE
 NISKAYUNA, NY 12309
 Ph: (518) 344-7490



THIS DRAWING EMBODIES A CONFIDENTIAL PROPRIETARY DESIGN. ALL RIGHTS FOR REPRODUCTION, MANUFACTURING OR PATENTS ARE RESERVED BY UNILUX ADVANCED MANUFACTURING, LLC.

Drawn By:	-	Date:	-
Checked By:	-	Date:	-
Drawing No.:	ZF 150HS-SUBMITTAL		
File No.:	QBXXX	REV.:	00