

FLUE GAS OUTLET CONNECTION		
FLANGE DIMENSIONS	in	mm
O.D.	31.00	787
I.D.	26.25	667
B.C.D	28.50	724
HOLE DIAMETER	0.53	13
No. OF HOLES	12	

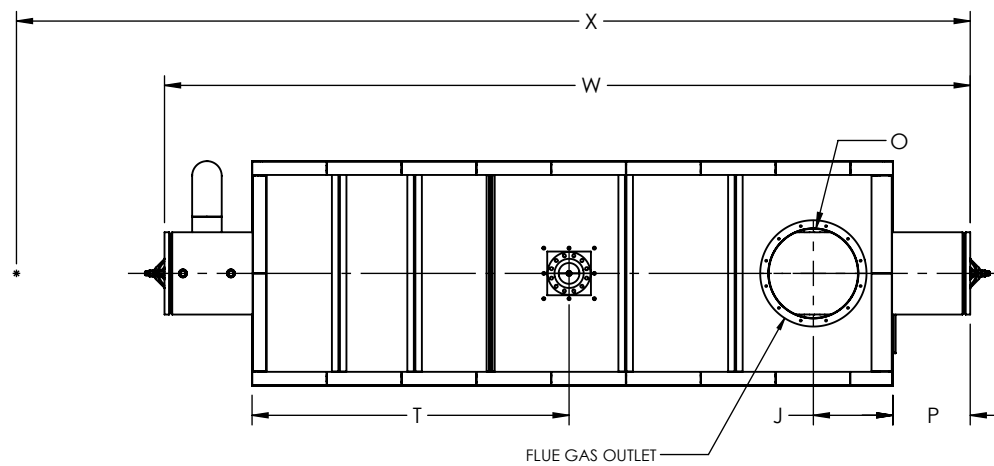

**TOP VIEW**

GENERAL DIMENSIONS		
	in	mm
A	186.88	4747
B	115.60	2936
C	65.50	1664
D	84.50	2146
E	13.81	351
F	42.63	1083
G	6.00	152
H	25.54	649
J	23.11	587
K	24.69	627
L	49.00	1245
M	24.00	610
N	12.75	324
O	26.00	660
P	22.64	575
Q	2.00	51
R	0.00	
S	19.50	495
T	92.46	2349
U	2.00	51
V	64.31	1633
W	235.00	5969
X	0.00	
Y	117.81	2992

NOTE: DIMENSIONS SUBJECT TO CHANGE WITHOUT NOTICE. CONSULT FACTORY FOR CERTIFIED DIMENSIONS.

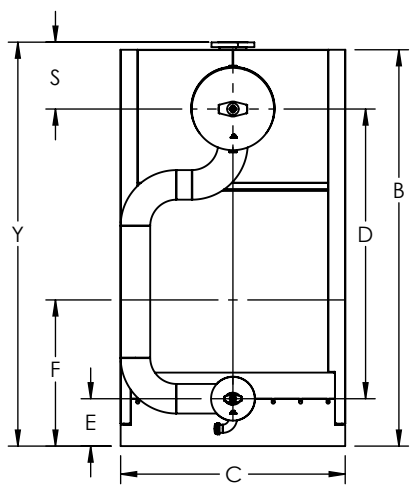

**FRONT VIEW**

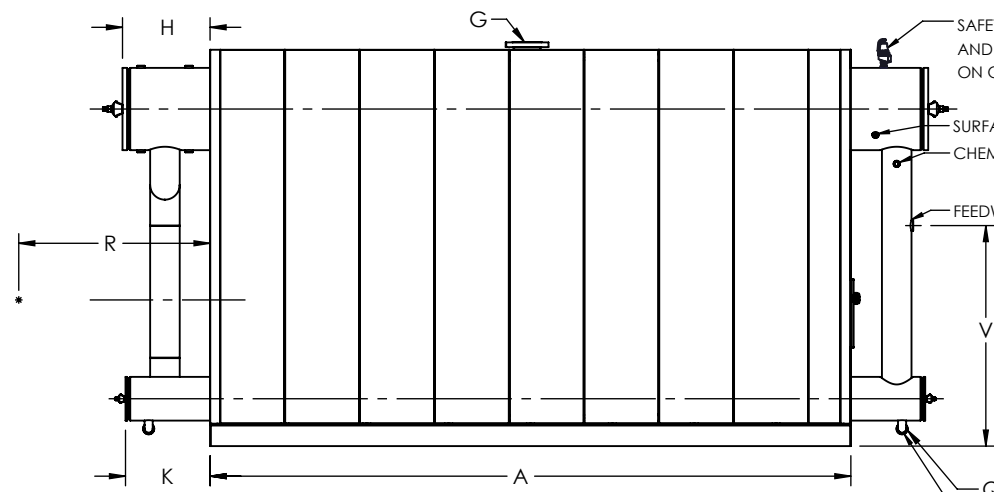

**SIDE VIEW**

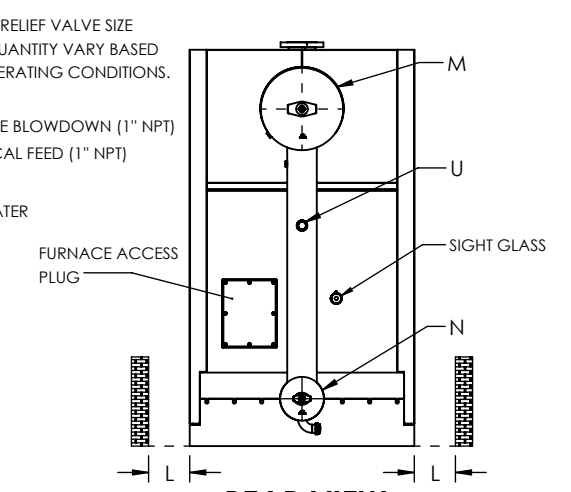

**REAR VIEW**

**UNILUX ADVANCED MFG., LLC.**  
 30 COMMERCE PARK DRIVE  
 NISKAYUNA, NY 12309  
 Ph: (518) 344-7490



THIS DRAWING EMBODIES A CONFIDENTIAL PROPRIETARY DESIGN. ALL RIGHTS FOR REPRODUCTION, MANUFACTURING OR PATENTS ARE RESERVED BY UNILUX ADVANCED MANUFACTURING, LLC.

PROJECT:	-
LOCATION:	-
MODEL:	ZF 1800HS
BURNER:	-
ELECTRIC:	-
SUPPLY PSI:	-

Drawn By:	-	Date:	-
Checked By:	-	Date:	-
Drawing No.:	ZF 1800HS-SUBMITTAL		
File No.:	QBXXX	REV.:	00

ZONE	REV.	DESCRIPTION	DATE
REVISIONS			