

FLUE GAS OUTLET CONNECTION		
FLANGE DIMENSIONS	in	mm
O.D.	31.00	787
I.D.	26.25	667
B.C.D	28.50	724
HOLE DIAMETER	0.53	13
No. OF HOLES	12	

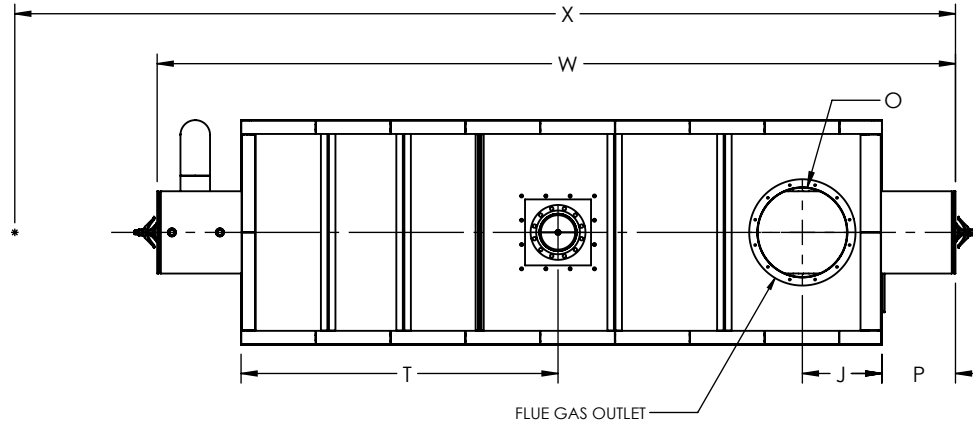

TOP VIEW

GENERAL DIMENSIONS		
	in	mm
A	186.88	4747
B	115.60	2936
C	65.50	1664
D	84.50	2146
E	13.81	351
F	42.63	1083
G	10.00	254
H	24.47	622
J	23.11	587
K	24.50	622
L	49.00	1245
M	24.00	610
N	12.75	324
O	26.00	660
P	21.42	544
Q	2.00	51
R	0.00	
S	18.50	470
T	92.45	2348
U	2.00	51
V	64.31	1633
W	232.85	5914
X	0.00	
Y	116.81	2967

NOTE: DIMENSIONS SUBJECT TO CHANGE WITHOUT NOTICE. CONSULT FACTORY FOR CERTIFIED DIMENSIONS.

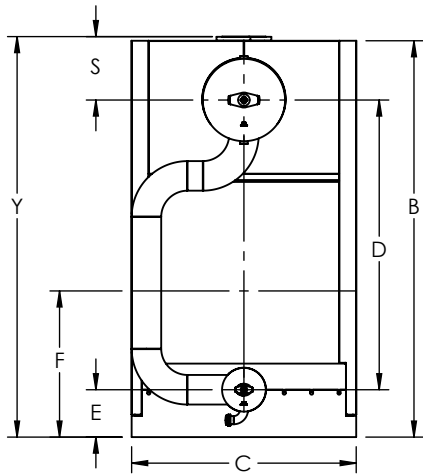

FRONT VIEW

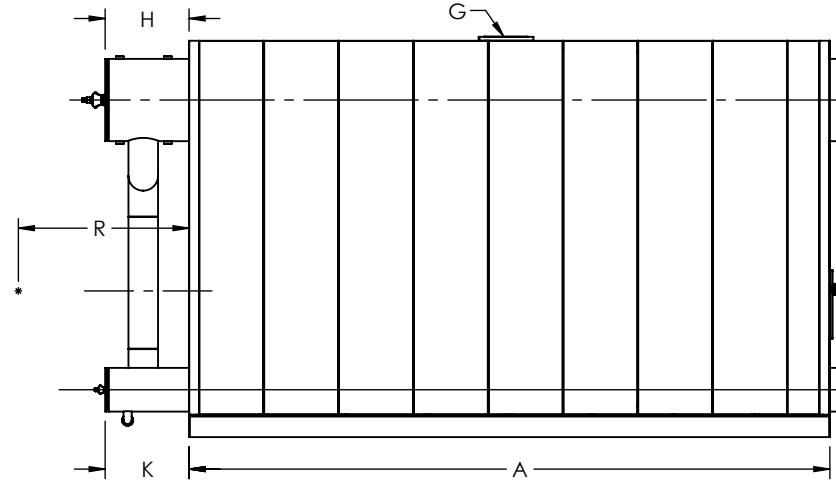

SIDE VIEW

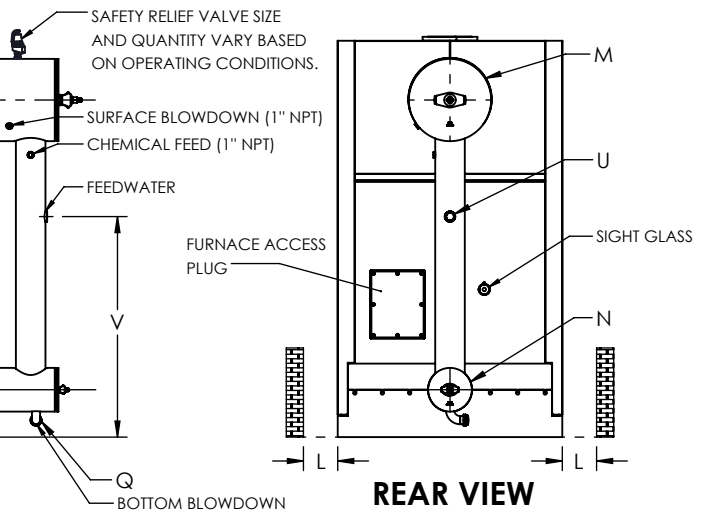

REAR VIEW

ZONE	REV.	DESCRIPTION	DATE
REVISIONS			

PROJECT:	-
LOCATION:	-
MODEL:	ZF 1800LS
BURNER:	-
ELECTRIC:	-
SUPPLY PSI:	-

UNILUX ADVANCED MFG., LLC.
 30 COMMERCE PARK DRIVE
 NISKAYUNA, NY 12309
 Ph: (518) 344-7490



THIS DRAWING EMBODIES A CONFIDENTIAL PROPRIETARY DESIGN. ALL RIGHTS FOR REPRODUCTION, MANUFACTURING OR PATENTS ARE RESERVED BY UNILUX ADVANCED MANUFACTURING, LLC.

Drawn By:	-	Date:	-
Checked By:	-	Date:	-
Drawing No.:	ZF 1800LS-SUBMITTAL		
File No.:	QBXXX	REV.:	00