

FLUE GAS OUTLET CONNECTION		
FLANGE DIMENSIONS	in	mm
O.D.	33.00	838
I.D.	28.25	718
B.C.D	30.50	775
HOLE DIAMETER	0.53	13
No. OF HOLES	12	

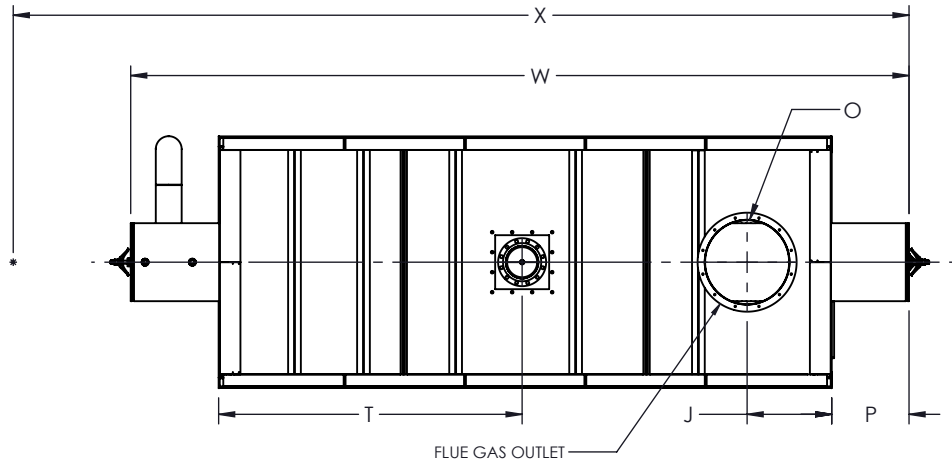

**TOP VIEW**

GENERAL DIMENSIONS		
	in	mm
A	BOILER BASE LENGTH	204.35 5190
B	BOILER HOUSING HEIGHT	136.97 3479
C	BOILER BASE WIDTH	84.00 2134
D	CENTER OF BOTTOM DRUM TO CENTER OF TOP DRUM	102.00 2591
E	CENTER OF BOTTOM DRUM TO BOTTOM	13.81 351
F	CENTER OF BURNER OPENING TO BOTTOM	50.38 1280
G	STEAM OUTLET, FLANGE, CLASS 150 (NPS)	10.00 254
H	TOP DRUM CLEARANCE FROM FRONT	29.42 747
J	CENTER OF FLUE GAS OUTLET TO REAR	28.08 713
K	BOTTOM DRUM CLEARANCE FROM FRONT	25.81 656
L	TUBE REMOVAL CLEARANCE FROM BASE	66.00 1676
M	UPPER DRUM, O.D.	26.00 660
N	LOWER DRUM, O.D.	12.75 324
O	FLUE GAS OUTLET, I.D.	28.00 711
P	TOP DRUM CLEARANCE FROM REAR	25.90 658
Q	BOTTOM BLOWDOWN (NPT)	2.00 51
R	BURNER LENGTH	0.00
S	CENTER OF TOP DRUM TO TOP OF STEAM OUTLET	23.00 584
T	CENTER OF STEAM OUTLET TO FRONT	101.05 2567
U	FEEDWATER INLET, FLANGE, CLASS 150 (NPS)	3.00 76
V	FEEDWATER ELEVATION FROM BOTTOM	78.81 2002
W	OVERALL BOILER LENGTH	259.44 6590
X	OVERALL BOILER LENGTH WITH BURNER	0.00
Y	OVERALL BOILER HEIGHT	138.81 3526

NOTE: DIMENSIONS SUBJECT TO CHANGE WITHOUT NOTICE. CONSULT FACTORY FOR CERTIFIED DIMENSIONS.

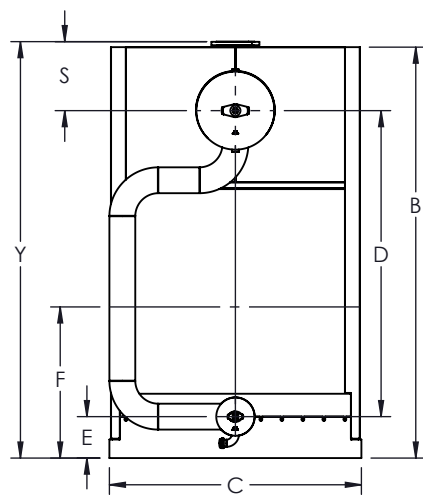

**FRONT VIEW**

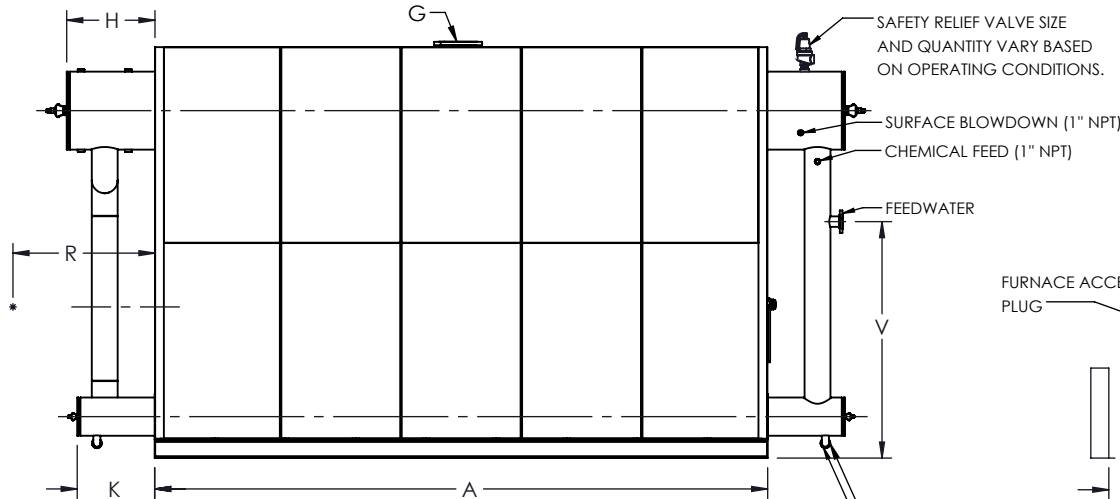

**SIDE VIEW**

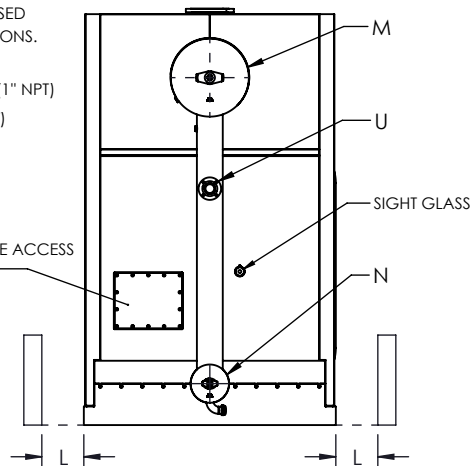

**REAR VIEW**

**UNILUX ADVANCED MFG., LLC.**  
 30 COMMERCE PARK DRIVE  
 NISKAYUNA, NY 12309  
 Ph: (518) 344-7490



THIS DRAWING EMBODIES A CONFIDENTIAL PROPRIETARY DESIGN. ALL RIGHTS FOR REPRODUCTION, MANUFACTURING OR PATENTS ARE RESERVED BY UNILUX ADVANCED MANUFACTURING, LLC.

Drawn By: -	Date: -
Checked By: -	Date: -
Drawing No. : ZF 2500LS-SUBMITTAL	
File No. : QBXXX	REV. : 00

PROJECT:	-
LOCATION:	-
MODEL:	ZF 2500LS
BURNER:	-
ELECTRIC:	-
SUPPLY PSI:	-

ZONE	REV.	DESCRIPTION	DATE
REVISIONS			