

FLUE GAS OUTLET CONNECTION		
FLANGE DIMENSIONS	in	mm
O.D.	15.00	381
I.D.	10.25	260
B.C.D	12.50	318
HOLE DIAMETER	0.53	13
No. OF HOLES	6	

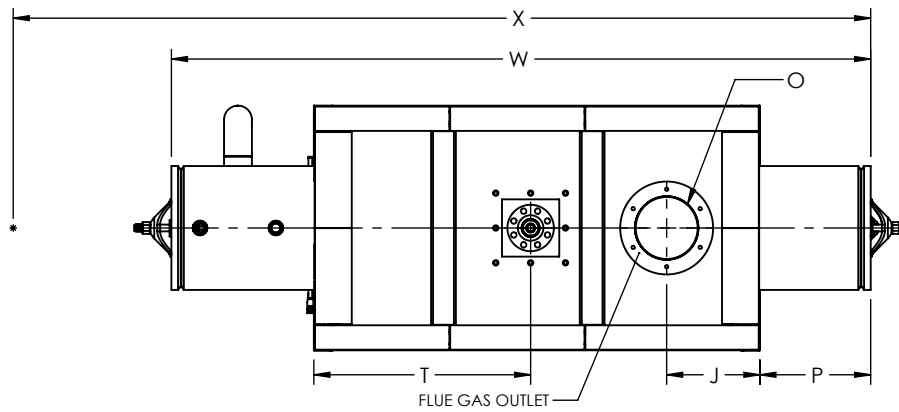

TOP VIEW

GENERAL DIMENSIONS		
	in	mm
A	BOILER BASE LENGTH	72.02 1829
B	BOILER HOUSING HEIGHT	83.66 2125
C	BOILER BASE WIDTH	39.50 1003
D	CENTER OF BOTTOM DRUM TO CENTER OF TOP DRUM	59.00 1499
E	CENTER OF BOTTOM DRUM TO BOTTOM	9.50 241
F	CENTER OF BURNER OPENING TO BOTTOM	27.81 706
G	STEAM OUTLET, FLANGE, CLASS 300 (NPS)	2.50 64
H	TOP DRUM CLEARANCE FROM FRONT	23.04 585
J	CENTER OF FLUE GAS OUTLET TO REAR	15.01 381
K	BOTTOM DRUM CLEARANCE FROM FRONT	17.38 441
L	TUBE REMOVAL CLEARANCE FROM BASE	23.00 584
M	UPPER DRUM, O.D.	20.00 508
N	LOWER DRUM, O.D.	8.63 219
O	FLUE GAS OUTLET, I.D.	10.00 254
P	TOP DRUM CLEARANCE FROM REAR	17.93 455
Q	BOTTOM BLOWDOWN (NPT)	1.50 38
R	BURNER LENGTH	0.00
S	CENTER OF TOP DRUM TO TOP OF STEAM OUTLET	16.50 419
T	CENTER OF STEAM OUTLET TO FRONT	34.96 888
U	FEEDWATER INLET, COUPLING (NPT)	1.25 32
V	FEEDWATER ELEVATION FROM BOTTOM	44.50 1130
W	OVERALL BOILER LENGTH	112.91 2868
X	OVERALL BOILER LENGTH WITH BURNER	0.00
Y	OVERALL BOILER HEIGHT	85.00 2159

NOTE: DIMENSIONS SUBJECT TO CHANGE WITHOUT NOTICE. CONSULT FACTORY FOR CERTIFIED DIMENSIONS.

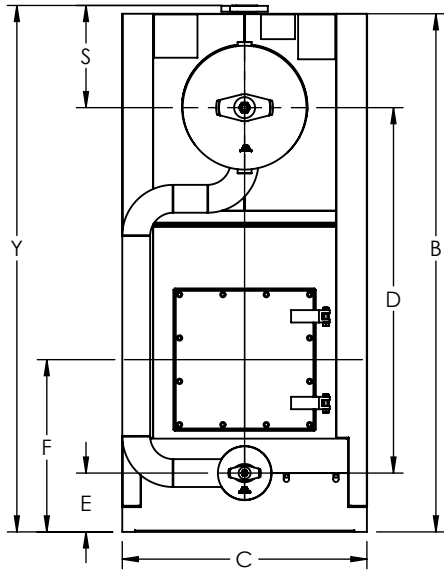

FRONT VIEW

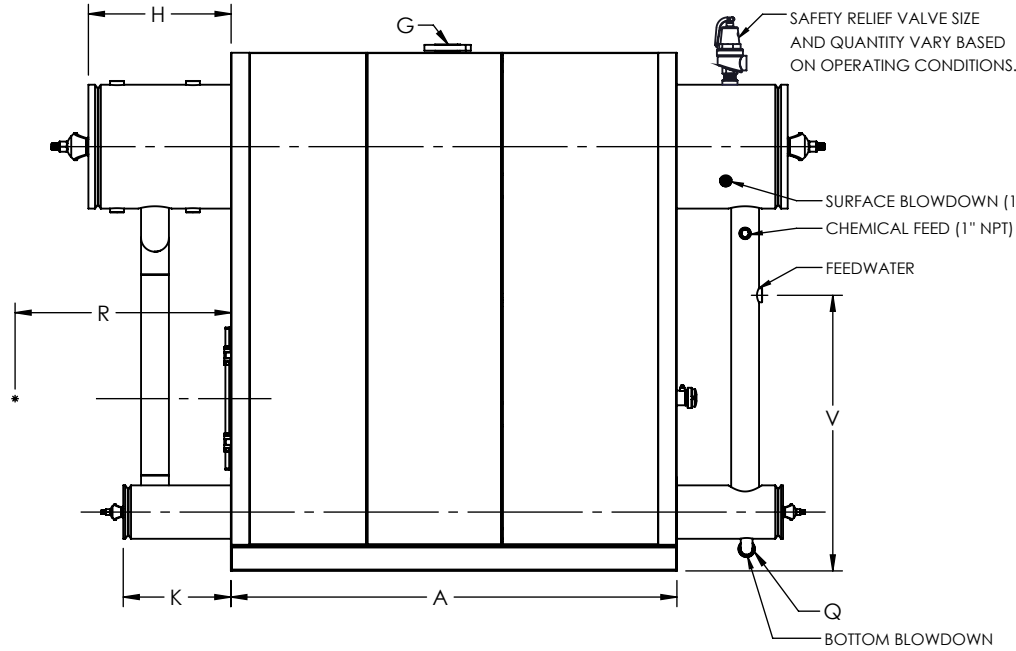

SIDE VIEW

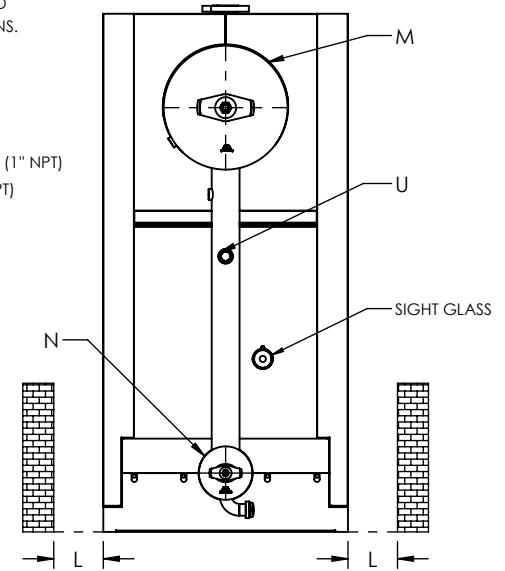

REAR VIEW

UNILUX ADVANCED MFG., LLC.

30 COMMERCE PARK DRIVE
NISKAYUNA, NY 12309
Ph: (518) 344-7490



THIS DRAWING EMBODIES A CONFIDENTIAL PROPRIETARY DESIGN. ALL RIGHTS FOR REPRODUCTION, MANUFACTURING OR PATENTS ARE RESERVED BY UNILUX ADVANCED MANUFACTURING, LLC.

PROJECT:	-
LOCATION:	-
MODEL:	ZF 250HS
BURNER:	-
ELECTRIC:	-
SUPPLY PSI:	-

Drawn By:	-	Date:	-
Checked By:	-	Date:	-
Drawing No.:	ZF 250HS-SUBMITTAL		
File No.:	QBXXX	REV.:	00

ZONE	REV.	DESCRIPTION	DATE
		REVISIONS	