

FLUE GAS OUTLET CONNECTION		
FLANGE DIMENSIONS	in	mm
O.D.	15.00	381
I.D.	10.25	260
B.C.D	12.50	318
HOLE DIAMETER	0.53	13
No. OF HOLES	6	

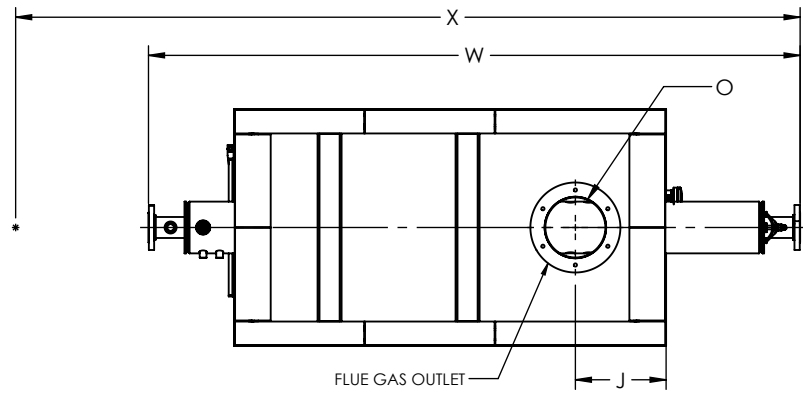

**TOP VIEW**

GENERAL DIMENSIONS		
	in	mm
A	72.02	1829
B	76.10	1933
C	39.50	1003
D	57.00	1448
E	9.50	241
F	29.00	737
G	3.00	76
H	14.29	363
J	15.08	383
K	1.75	44
L	23.00	584
M	8.63	219
N	8.63	219
O	10.00	254
P	22.34	567
Q	1.50	38
R	0.00	0
W	108.61	2759
X	0.00	0

NOTE: DIMENSIONS SUBJECT TO CHANGE WITHOUT NOTICE. CONSULT FACTORY FOR CERTIFIED DIMENSIONS.

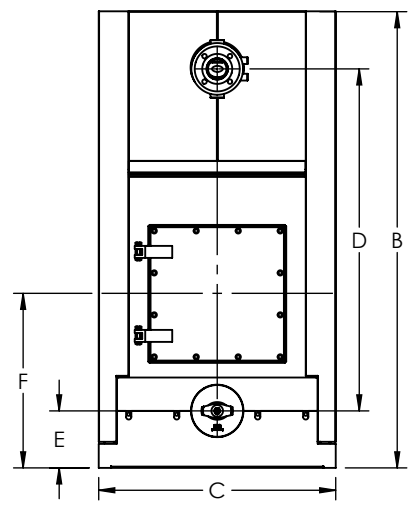

**FRONT VIEW**

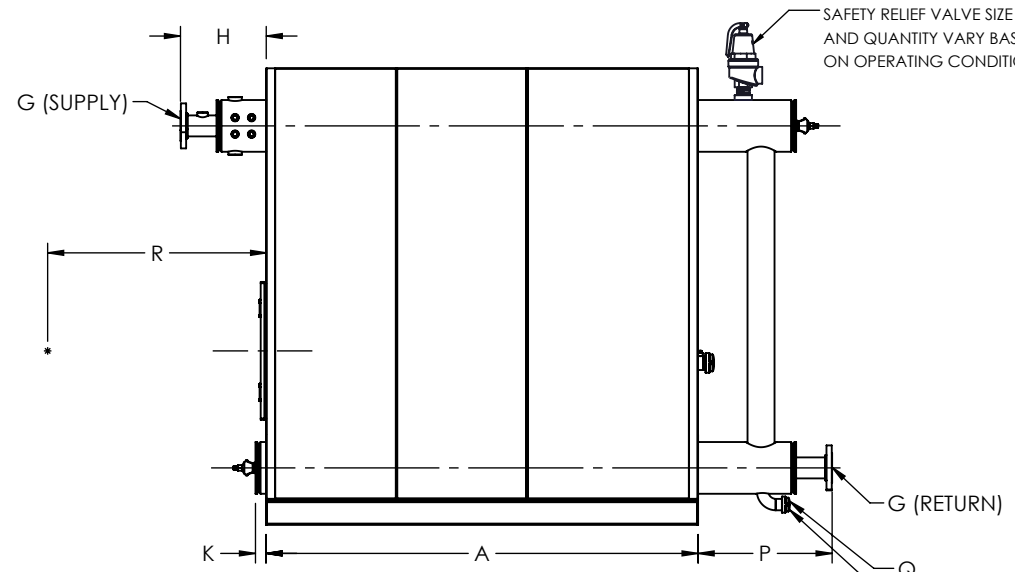

**SIDE VIEW**

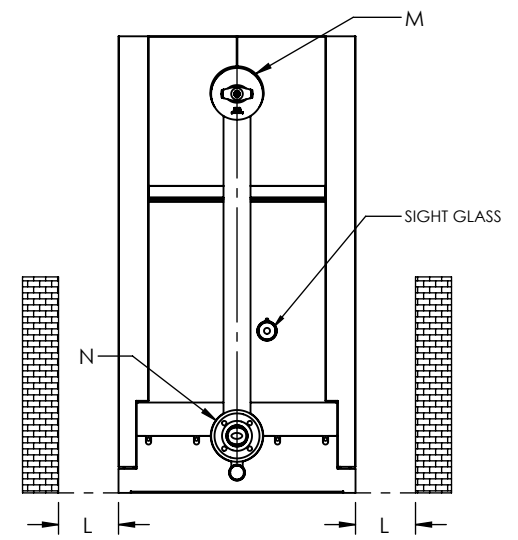

**REAR VIEW**

ZONE	REV.	DESCRIPTION	DATE
REVISIONS			

PROJECT:	-
LOCATION:	-
MODEL:	ZF 250W
BURNER:	-
ELECTRIC:	-
SUPPLY PSI:	-

**UNILUX ADVANCED MFG., LLC.**  
 30 COMMERCE PARK DRIVE  
 NISKAYUNA, NY 12309  
 Ph: (518) 344-7490



THIS DRAWING EMBODIES A CONFIDENTIAL PROPRIETARY DESIGN. ALL RIGHTS FOR REPRODUCTION, MANUFACTURING OR PATENTS ARE RESERVED BY UNILUX ADVANCED MANUFACTURING, LLC.

Drawn By:	-	Date:	-
Checked By:	-	Date:	-
Drawing No.:	ZF 250W-SUBMITTAL		
File No.:	QBXXX	REV.:	00