

FLUE GAS OUTLET CONNECTION		
FLANGE DIMENSIONS	in	mm
O.D.	35.00	889
I.D.	30.25	768
B.C.D	32.50	826
HOLE DIAMETER	0.53	13
No. OF HOLES	12	

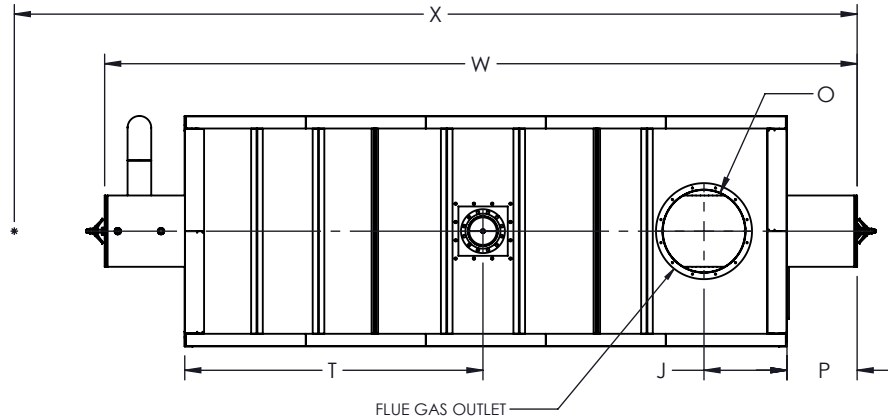

**TOP VIEW**

GENERAL DIMENSIONS		
	in	mm
A	BOILER BASE LENGTH	219.44 5574
B	BOILER HOUSING HEIGHT	141.85 3603
C	BOILER BASE WIDTH	84.00 2134
D	CENTER OF BOTTOM DRUM TO CENTER OF TOP DRUM	108.00 2743
E	CENTER OF BOTTOM DRUM TO BOTTOM	13.81 351
F	CENTER OF BURNER OPENING TO BOTTOM	52.38 1330
G	STEAM OUTLET, FLANGE, CLASS 150 (NPS)	10.00 254
H	TOP DRUM CLEARANCE FROM FRONT	29.17 741
J	CENTER OF FLUE GAS OUTLET TO REAR	30.26 769
K	BOTTOM DRUM CLEARANCE FROM FRONT	25.75 654
L	TUBE REMOVAL CLEARANCE FROM BASE	66.00 1676
M	UPPER DRUM, O.D.	26.00 660
N	LOWER DRUM, O.D.	12.75 324
O	FLUE GAS OUTLET, I.D.	30.00 762
P	TOP DRUM CLEARANCE FROM REAR	25.58 650
Q	BOTTOM BLOWDOWN (NPT)	2.00 51
R	BURNER LENGTH	0.00
S	CENTER OF TOP DRUM TO TOP OF STEAM OUTLET	23.00 584
T	CENTER OF STEAM OUTLET TO FRONT	108.75 2762
U	FEEDWATER INLET, FLANGE, CLASS 150 (NPS)	3.00 76
V	FEEDWATER ELEVATION FROM BOTTOM	84.81 2154
W	OVERALL BOILER LENGTH	274.35 6968
X	OVERALL BOILER LENGTH WITH BURNER	0.00
Y	OVERALL BOILER HEIGHT	144.81 3678

NOTE: DIMENSIONS SUBJECT TO CHANGE WITHOUT NOTICE. CONSULT FACTORY FOR CERTIFIED DIMENSIONS.

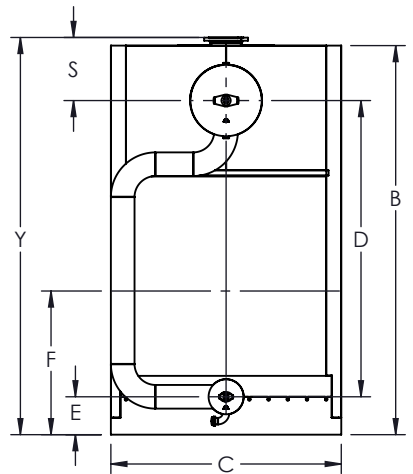

**FRONT VIEW**

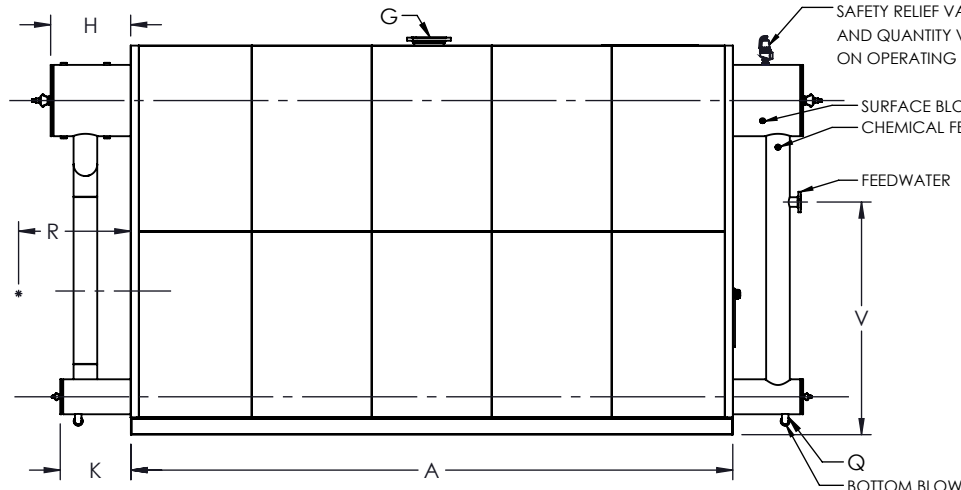

**SIDE VIEW**

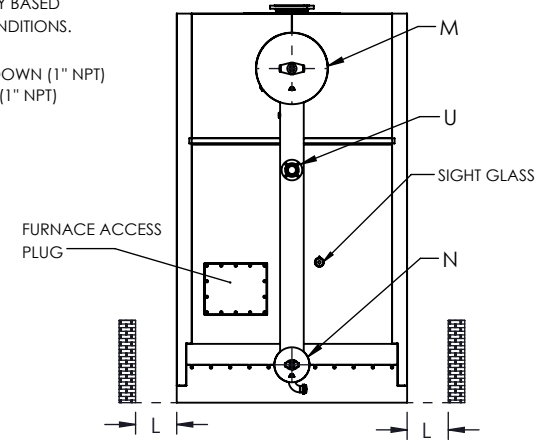

**REAR VIEW**

**UNILUX ADVANCED MFG., LLC.**  
 30 COMMERCE PARK DRIVE  
 NISKAYUNA, NY 12309  
 Ph: (518) 344-7490



THIS DRAWING EMBODIES A CONFIDENTIAL PROPRIETARY DESIGN. ALL RIGHTS FOR REPRODUCTION, MANUFACTURING OR PATENTS ARE RESERVED BY UNILUX ADVANCED MANUFACTURING, LLC.

Drawn By: -	Date: -
Checked By: -	Date: -
Drawing No. : ZF 2900LS-SUBMITTAL	
File No. : QBXXX	REV. : 00

PROJECT:	-
LOCATION:	-
MODEL:	ZF 2900LS
BURNER:	-
ELECTRIC:	-
SUPPLY PSI:	-

ZONE	REV.	DESCRIPTION	DATE
REVISIONS			