

FLUE GAS OUTLET CONNECTION		
FLANGE DIMENSIONS	in	mm
O.D.	17.00	432
I.D.	12.25	311
B.C.D	14.50	368
HOLE DIAMETER	0.53	13
No. OF HOLES	8	

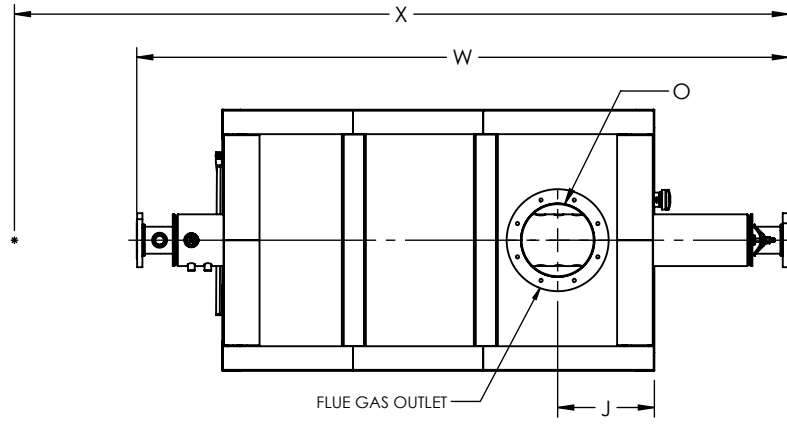

TOP VIEW

GENERAL DIMENSIONS		
	in	mm
A	72.02	1829
B	80.41	2042
C	43.50	1105
D	61.50	1562
E	9.50	241
F	31.00	787
G	4.00	102
H	14.31	363
J	16.06	408
K	1.75	44
L	27.00	686
M	8.63	219
N	8.63	219
O	12.00	305
P	22.34	567
Q	1.50	38
R	0.00	0
W	108.61	2759
X	0.00	0

NOTE: DIMENSIONS SUBJECT TO CHANGE WITHOUT NOTICE. CONSULT FACTORY FOR CERTIFIED DIMENSIONS.

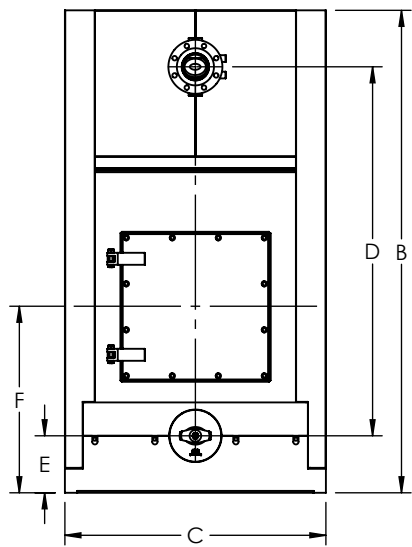

FRONT VIEW

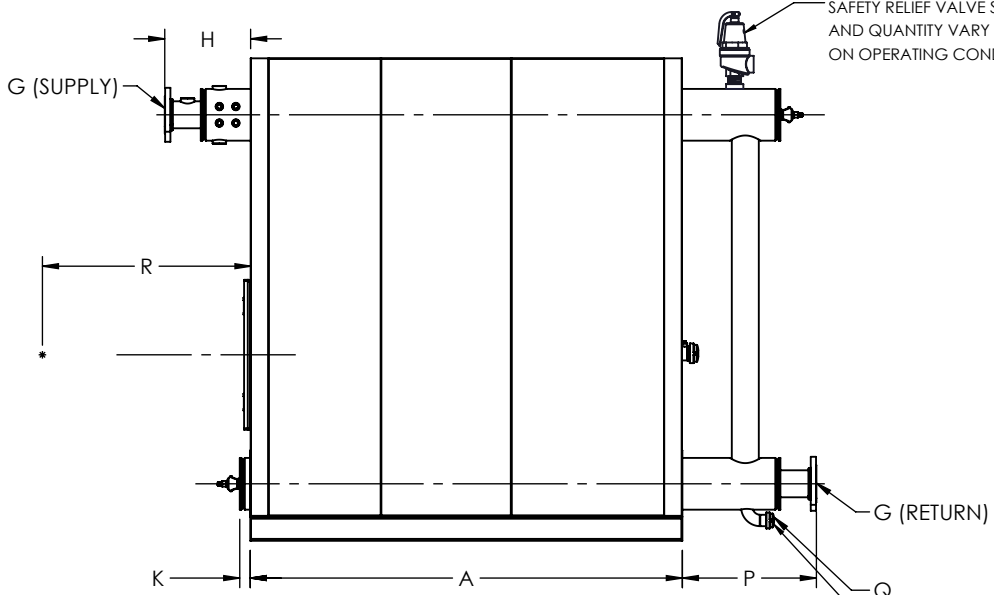

SIDE VIEW

SAFETY RELIEF VALVE SIZE AND QUANTITY VARY BASED ON OPERATING CONDITIONS.

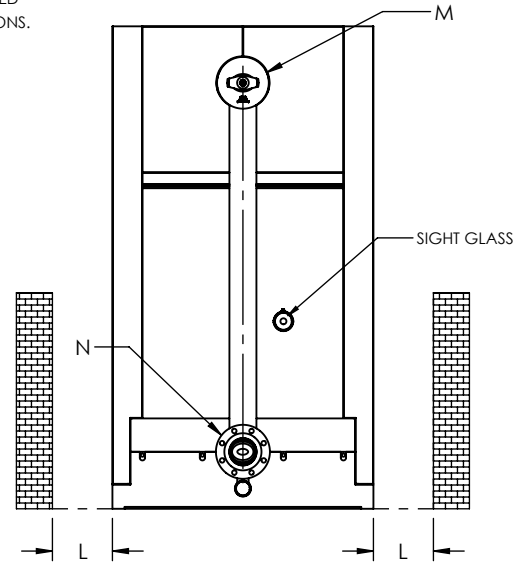

REAR VIEW

UNILUX ADVANCED MFG., LLC.
 30 COMMERCE PARK DRIVE
 NISKAYUNA, NY 12309
 Ph: (518) 344-7490



THIS DRAWING EMBODIES A CONFIDENTIAL PROPRIETARY DESIGN. ALL RIGHTS FOR REPRODUCTION, MANUFACTURING OR PATENTS ARE RESERVED BY UNILUX ADVANCED MANUFACTURING, LLC.

Drawn By: -	Date: -
Checked By: -	Date: -
Drawing No. : ZF 300W-SUBMITTAL	
File No. : QBXXX	REV. : 00

PROJECT:	-
LOCATION:	-
MODEL:	ZF 300W
BURNER:	-
ELECTRIC:	-
SUPPLY PSI:	-

ZONE	REV.	DESCRIPTION	DATE
REVISIONS			