

FLUE GAS OUTLET CONNECTION		
FLANGE DIMENSIONS	in	mm
O.D.	17.00	432
I.D.	12.25	311
B.C.D	14.50	368
HOLE DIAMETER	0.53	13
No. OF HOLES	8	

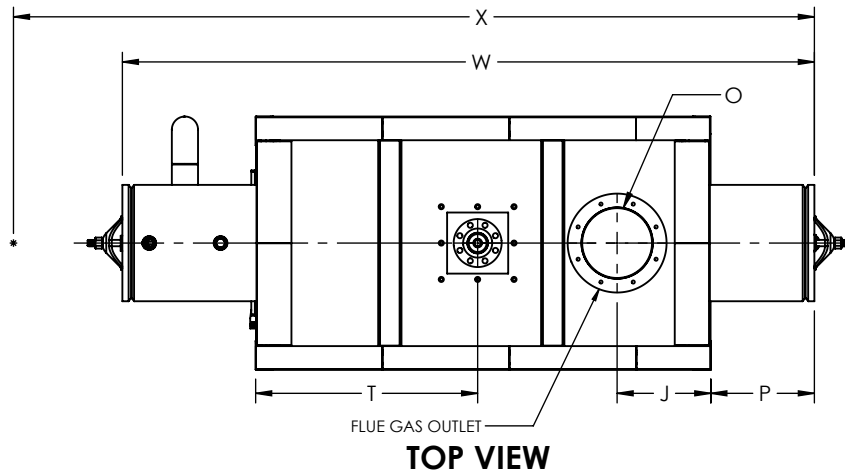

GENERAL DIMENSIONS		
	in	mm
A	78.05	1983
B	88.66	2252
C	43.50	1105
D	64.00	1626
E	9.50	241
F	29.36	746
G	3.00	76
H	22.91	582
J	16.11	409
K	17.41	442
L	27.00	686
M	20.00	508
N	8.63	219
O	12.00	305
P	17.80	452
Q	1.50	38
R	0.00	
S	16.50	419
T	38.16	969
U	1.25	32
V	49.50	1257
W	118.94	3021
X	0.00	
Y	90.00	2286

NOTE: DIMENSIONS SUBJECT TO CHANGE WITHOUT NOTICE. CONSULT FACTORY FOR CERTIFIED DIMENSIONS.

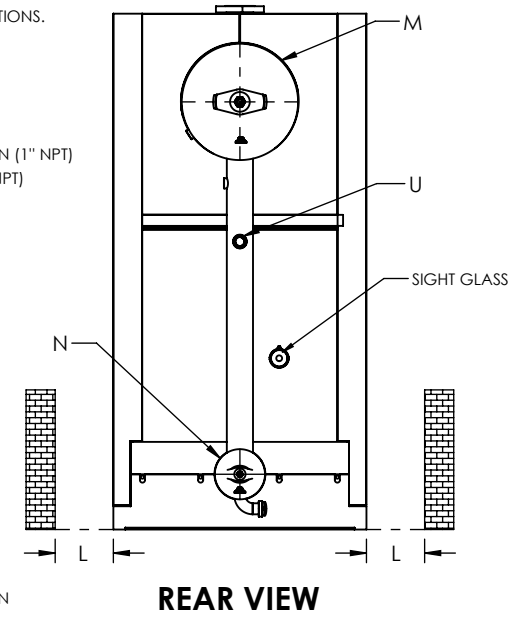
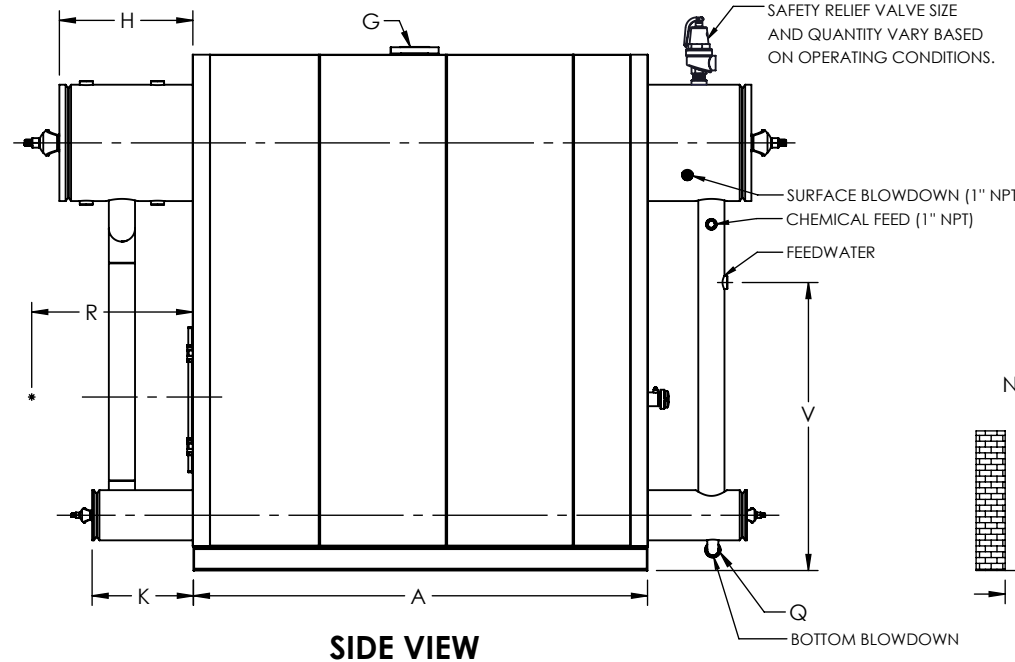
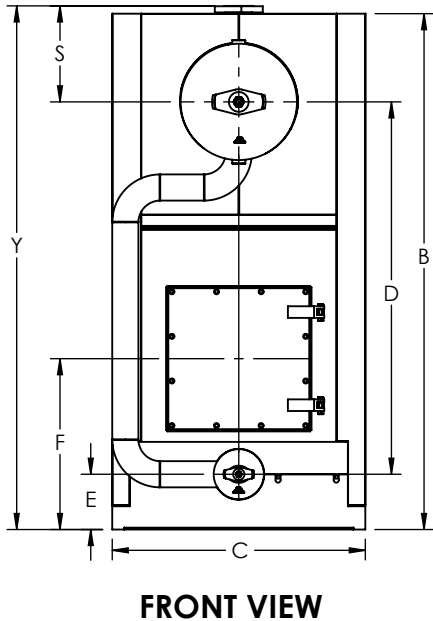

UNILUX ADVANCED MFG., LLC.
 30 COMMERCE PARK DRIVE
 NISKAYUNA, NY 12309
 Ph: (518) 344-7490

THIS DRAWING EMBODIES A CONFIDENTIAL PROPRIETARY DESIGN. ALL RIGHTS FOR REPRODUCTION, MANUFACTURING OR PATENTS ARE RESERVED BY UNILUX ADVANCED MANUFACTURING, LLC.

Drawn By: -	Date: -
Checked By: -	Date: -
Drawing No. : ZF 350HS-SUBMITTAL	
File No. : QBXXX	REV. : 00

PROJECT:	-
LOCATION:	-
MODEL:	ZF 350HS
BURNER:	-
ELECTRIC:	-
SUPPLY PSI:	-

ZONE	REV.	DESCRIPTION	DATE
REVISIONS			