

FLUE GAS OUTLET CONNECTION		
FLANGE DIMENSIONS	in	mm
O.D.	17.00	432
I.D.	12.25	311
B.C.D	14.50	368
HOLE DIAMETER	0.53	13
No. OF HOLES	8	

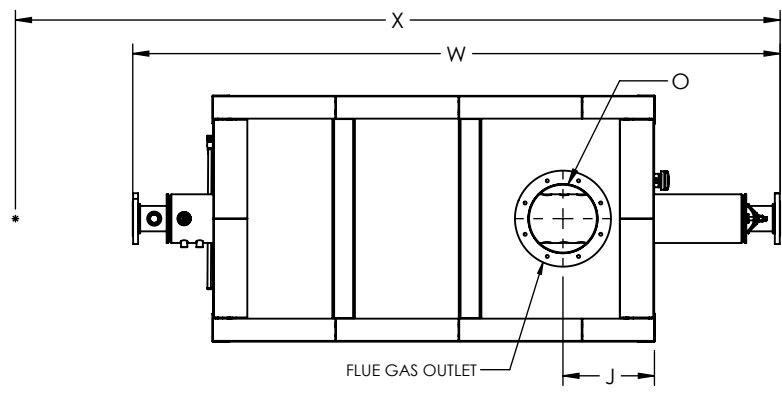

TOP VIEW

GENERAL DIMENSIONS		
	in	mm
A	78.05	1983
B	80.29	2039
C	43.50	1105
D	61.50	1562
E	9.50	241
F	31.00	787
G	4.00	102
H	14.13	359
J	16.24	412
K	1.75	44
L	27.00	686
M	8.63	219
N	8.63	219
O	12.00	305
P	22.34	567
Q	1.50	38
R	0.00	0
W	114.64	2912
X	0.00	0

NOTE: DIMENSIONS SUBJECT TO CHANGE WITHOUT NOTICE. CONSULT FACTORY FOR CERTIFIED DIMENSIONS.

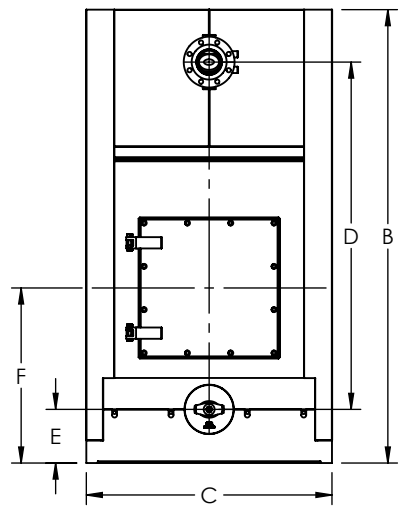

FRONT VIEW

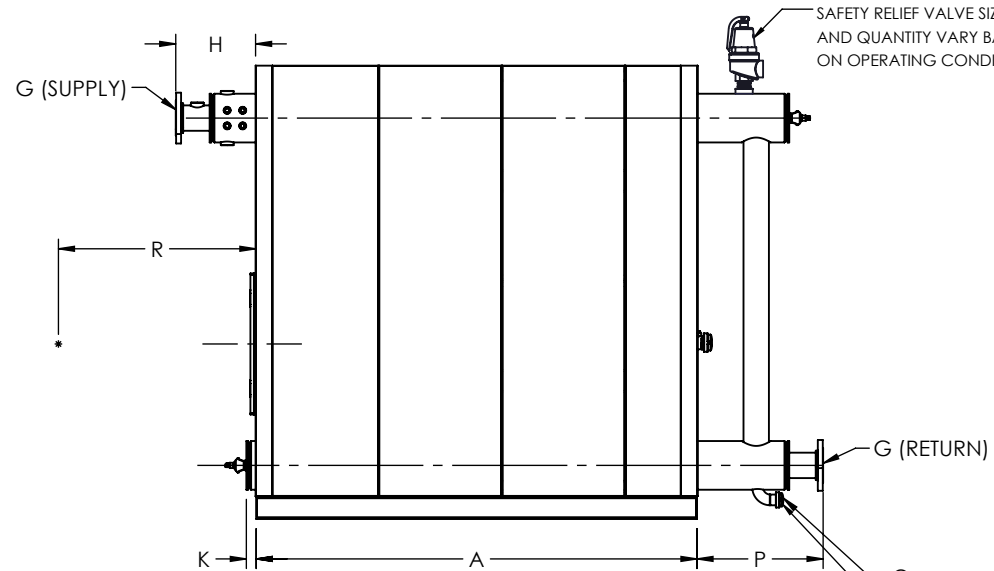

SIDE VIEW

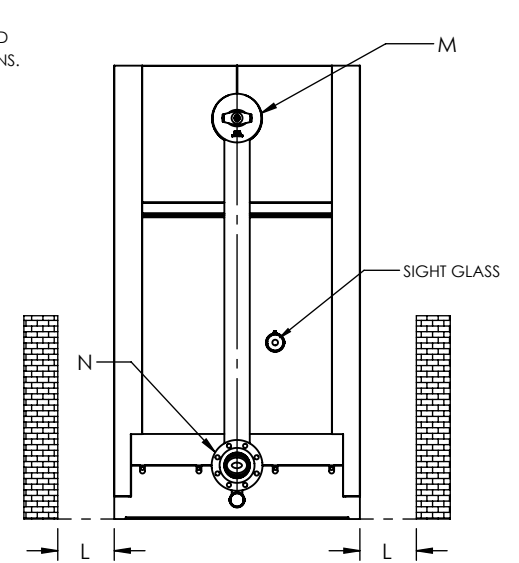

REAR VIEW

ZONE	REV.	DESCRIPTION	DATE
REVISIONS			

PROJECT:	-
LOCATION:	-
MODEL:	ZF 350W
BURNER:	-
ELECTRIC:	-
SUPPLY PSI:	-

UNILUX ADVANCED MFG., LLC.
 30 COMMERCE PARK DRIVE
 NISKAYUNA, NY 12309
 Ph: (518) 344-7490



THIS DRAWING EMBODIES A CONFIDENTIAL PROPRIETARY DESIGN. ALL RIGHTS FOR REPRODUCTION, MANUFACTURING OR PATENTS ARE RESERVED BY UNILUX ADVANCED MANUFACTURING, LLC.

Drawn By:	-	Date:	-
Checked By:	-	Date:	-
Drawing No.:	ZF 350W-SUBMITTAL		
File No.:	QBXXX	REV.:	00