

FLUE GAS OUTLET CONNECTION		
FLANGE DIMENSIONS	in	mm
O.D.	19.00	483
I.D.	14.25	362
B.C.D	16.50	419
HOLE DIAMETER	0.53	13
No. OF HOLES	8	

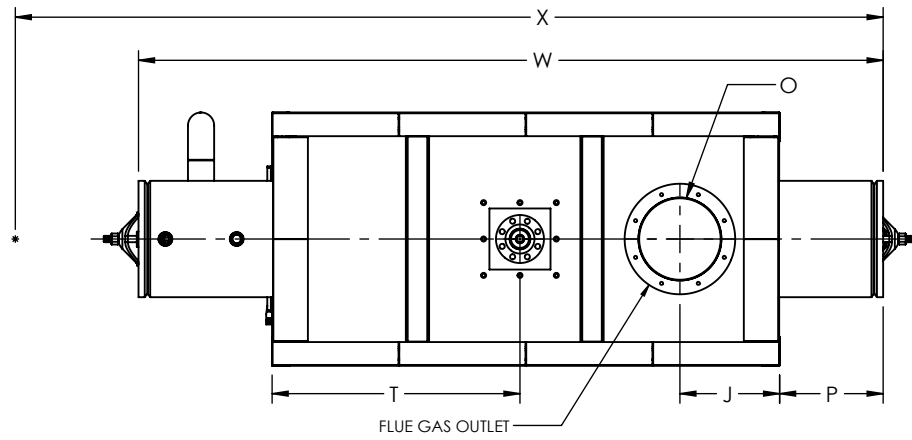

GENERAL DIMENSIONS		
	in	mm
A	BOILER BASE LENGTH	87.10 2212
B	BOILER HOUSING HEIGHT	88.66 2252
C	BOILER BASE WIDTH	43.50 1105
D	CENTER OF BOTTOM DRUM TO CENTER OF TOP DRUM	64.00 1626
E	CENTER OF BOTTOM DRUM TO BOTTOM	9.50 241
F	CENTER OF BURNER OPENING TO BOTTOM	29.36 746
G	STEAM OUTLET, FLANGE, CLASS 300 (NPS)	3.00 76
H	TOP DRUM CLEARANCE FROM FRONT	22.96 583
J	CENTER OF FLUE GAS OUTLET TO REAR	17.13 435
K	BOTTOM DRUM CLEARANCE FROM FRONT	17.39 442
L	TUBE REMOVAL CLEARANCE FROM BASE	27.00 686
M	UPPER DRUM, O.D.	20.00 508
N	LOWER DRUM, O.D.	8.63 219
O	FLUE GAS OUTLET, I.D.	14.00 356
P	TOP DRUM CLEARANCE FROM REAR	17.80 452
Q	BOTTOM BLOWDOWN (NPT)	1.50 38
R	BURNER LENGTH	0.00
S	CENTER OF TOP DRUM TO TOP OF STEAM OUTLET	16.50 419
T	CENTER OF STEAM OUTLET TO FRONT	42.60 1082
U	FEEDWATER INLET, COUPLING (NPT)	1.25 32
V	FEEDWATER ELEVATION FROM BOTTOM	49.50 1257
W	OVERALL BOILER LENGTH	127.98 3251
X	OVERALL BOILER LENGTH WITH BURNER	0.00
Y	OVERALL BOILER HEIGHT	90.00 2286

NOTE: DIMENSIONS SUBJECT TO CHANGE WITHOUT NOTICE. CONSULT FACTORY FOR CERTIFIED DIMENSIONS.

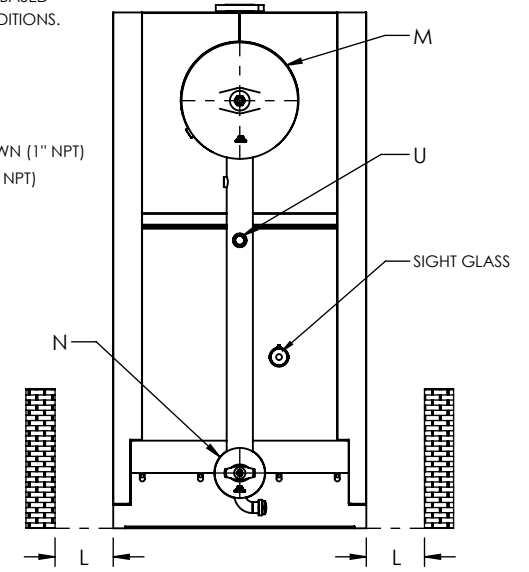
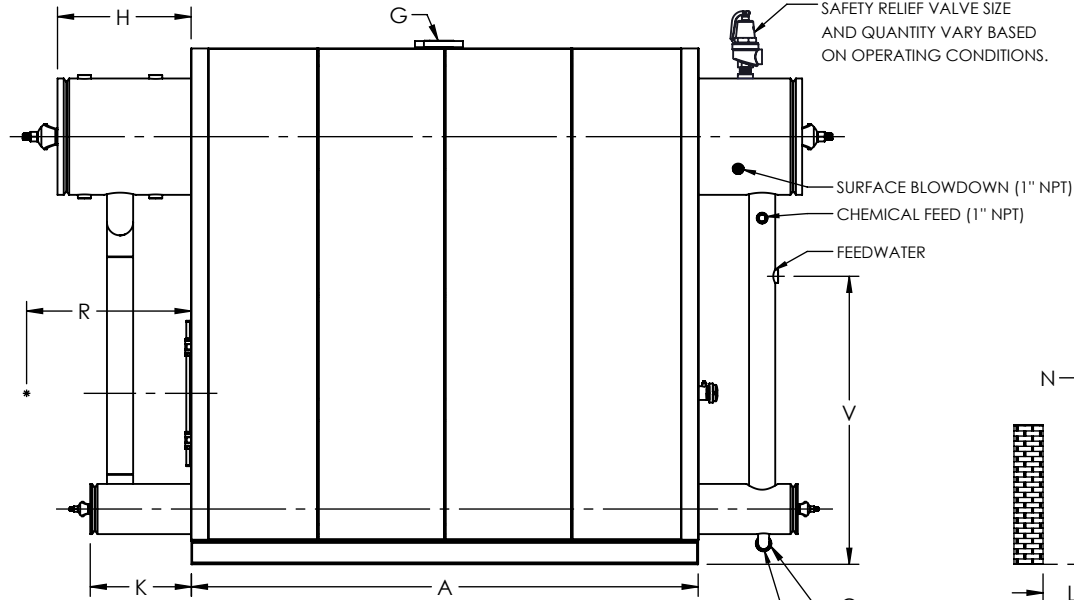
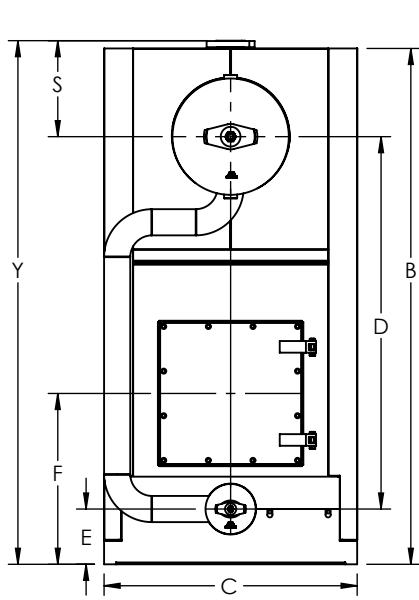

FRONT VIEW

SIDE VIEW

REAR VIEW

**UNILUX ADVANCED MFG., LLC.**

30 COMMERCE PARK DRIVE  
 NISKAYUNA, NY 12309  
 Ph: (518) 344-7490



THIS DRAWING EMBODIES A CONFIDENTIAL PROPRIETARY DESIGN. ALL RIGHTS FOR REPRODUCTION, MANUFACTURING OR PATENTS ARE RESERVED BY UNILUX ADVANCED MANUFACTURING, LLC.

PROJECT:	-
LOCATION:	-
MODEL:	ZF 400HS
BURNER:	-
ELECTRIC:	-
SUPPLY PSI:	-

Drawn By:	-	Date:	-
Checked By:	-	Date:	-
Drawing No.:	ZF 400HS-SUBMITTAL		
File No.:	QBXXX	REV.:	00

ZONE	REV.	DESCRIPTION	DATE
		REVISIONS	