

FLUE GAS OUTLET CONNECTION		
FLANGE DIMENSIONS	in	mm
O.D.	19.00	483
I.D.	14.25	362
B.C.D	16.50	419
HOLE DIAMETER	0.53	13
No. OF HOLES	8	

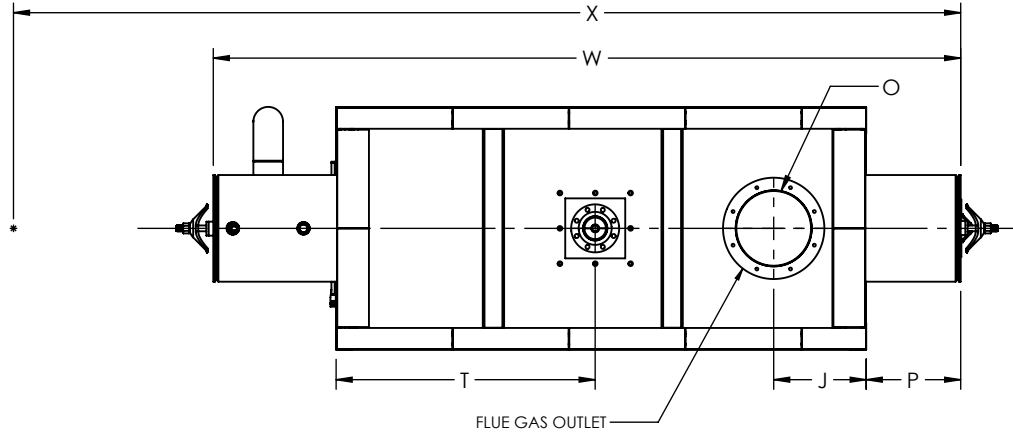

TOP VIEW

GENERAL DIMENSIONS		
	in	mm
A	BOILER BASE LENGTH	99.16 2519
B	BOILER HOUSING HEIGHT	92.85 2358
C	BOILER BASE WIDTH	45.50 1156
D	CENTER OF BOTTOM DRUM TO CENTER OF TOP DRUM	67.00 1702
E	CENTER OF BOTTOM DRUM TO BOTTOM	10.69 272
F	CENTER OF BURNER OPENING TO BOTTOM	33.00 838
G	STEAM OUTLET, FLANGE, CLASS 150 (NPS)	4.00 102
H	TOP DRUM CLEARANCE FROM FRONT	23.08 586
J	CENTER OF FLUE GAS OUTLET TO REAR	17.35 441
K	BOTTOM DRUM CLEARANCE FROM FRONT	18.31 465
L	TUBE REMOVAL CLEARANCE FROM BASE	29.00 737
M	UPPER DRUM, O.D.	20.00 508
N	LOWER DRUM, O.D.	10.75 273
O	FLUE GAS OUTLET, I.D.	14.00 356
P	TOP DRUM CLEARANCE FROM REAR	17.72 450
Q	BOTTOM BLOWDOWN (NPT)	1.50 38
R	BURNER LENGTH	0.00
S	CENTER OF TOP DRUM TO TOP OF STEAM OUTLET	16.50 419
T	CENTER OF STEAM OUTLET TO FRONT	48.53 1233
U	FEEDWATER INLET, COUPLING (NPT)	1.50 38
V	FEEDWATER ELEVATION FROM BOTTOM	47.69 1211
W	OVERALL BOILER LENGTH	140.14 3560
X	OVERALL BOILER LENGTH WITH BURNER	0.00
Y	OVERALL BOILER HEIGHT	94.19 2392

NOTE: DIMENSIONS SUBJECT TO CHANGE WITHOUT NOTICE. CONSULT FACTORY FOR CERTIFIED DIMENSIONS.

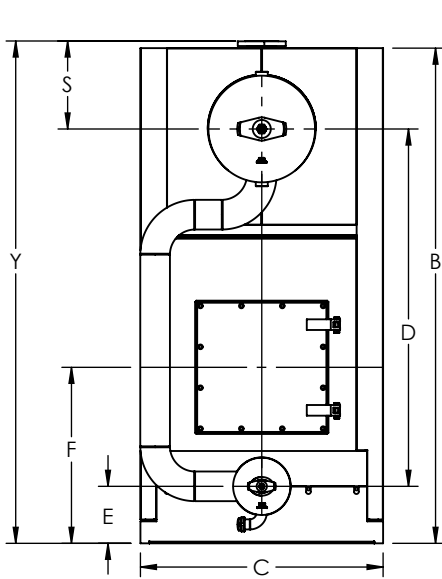

FRONT VIEW

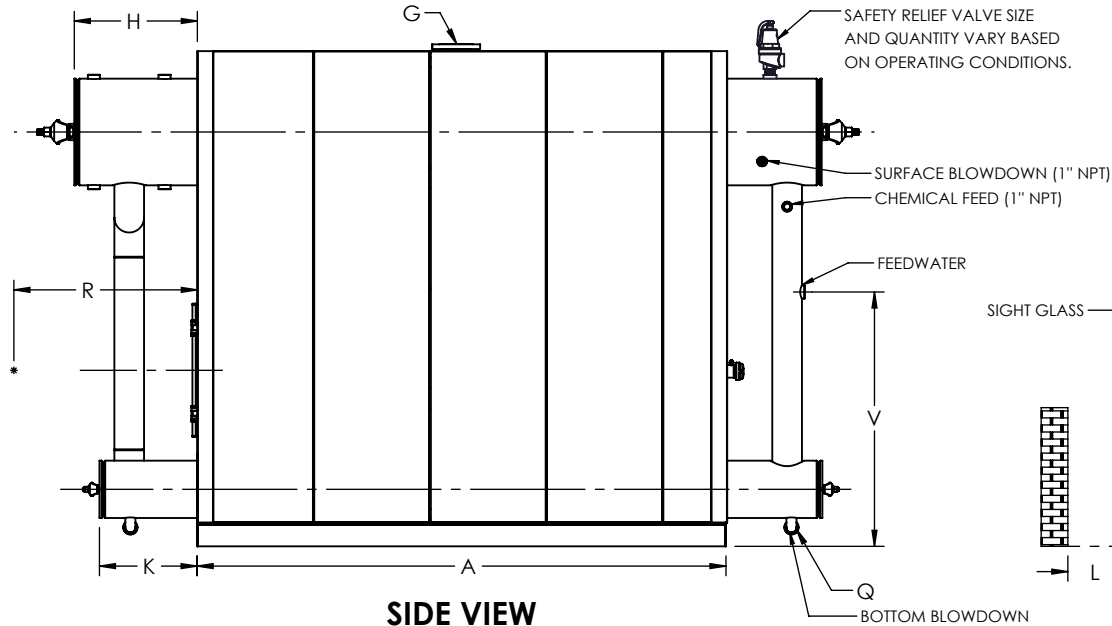

SIDE VIEW

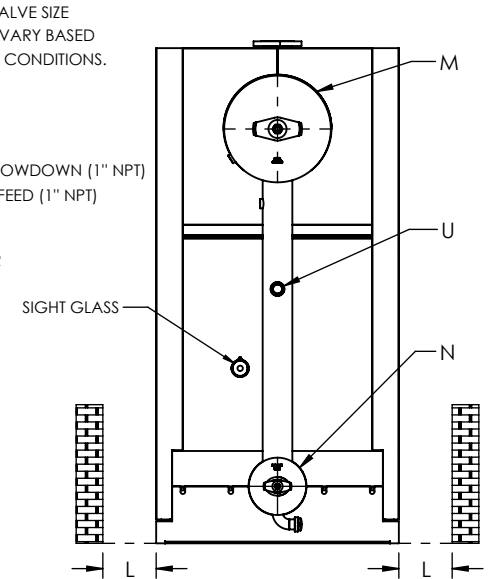

REAR VIEW

UNILUX ADVANCED MFG., LLC.

30 COMMERCE PARK DRIVE
NISKAYUNA, NY 12309
Ph: (518) 344-7490



THIS DRAWING EMBODIES A CONFIDENTIAL PROPRIETARY DESIGN. ALL RIGHTS FOR REPRODUCTION, MANUFACTURING OR PATENTS ARE RESERVED BY UNILUX ADVANCED MANUFACTURING, LLC.

PROJECT:	-
LOCATION:	-
MODEL:	ZF 500LS
BURNER:	-
ELECTRIC:	-
SUPPLY PSI:	-

Drawn By:	-	Date:	-
Checked By:	-	Date:	-
Drawing No.:	ZF 500LS-SUBMITTAL		
File No.:	QBXXX	REV.:	00

ZONE	REV.	DESCRIPTION	DATE
		REVISIONS	