

FLUE GAS OUTLET CONNECTION		
FLANGE DIMENSIONS	in	mm
O.D.	23.00	584
I.D.	18.25	464
B.C.D	20.50	521
HOLE DIAMETER	0.53	13
No. OF HOLES	8	

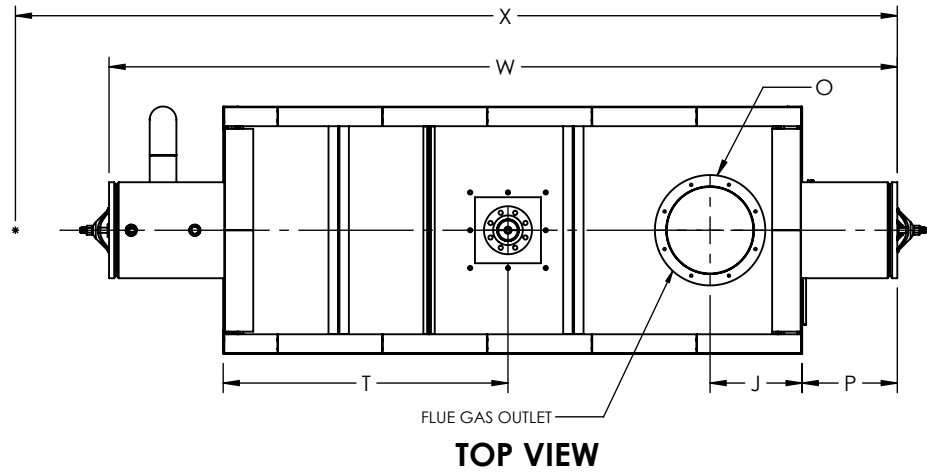

GENERAL DIMENSIONS			
	in	mm	
A	BOILER BASE LENGTH	120.63	3064
B	BOILER HOUSING HEIGHT	102.85	2612
C	BOILER BASE WIDTH	51.50	1308
D	CENTER OF BOTTOM DRUM TO CENTER OF TOP DRUM	75.00	1905
E	CENTER OF BOTTOM DRUM TO BOTTOM	12.81	325
F	CENTER OF BURNER OPENING TO BOTTOM	38.31	973
G	STEAM OUTLET, FLANGE, CLASS 300 (NPS)	4.00	102
H	TOP DRUM CLEARANCE FROM FRONT	23.89	607
J	CENTER OF FLUE GAS OUTLET TO REAR	19.08	485
K	BOTTOM DRUM CLEARANCE FROM FRONT	18.31	465
L	TUBE REMOVAL CLEARANCE FROM BASE	35.00	889
M	UPPER DRUM, O.D.	20.00	508
N	LOWER DRUM, O.D.	10.75	273
O	FLUE GAS OUTLET, I.D.	18.00	457
P	TOP DRUM CLEARANCE FROM REAR	19.92	506
Q	BOTTOM BLOWDOWN (NPT)	1.50	38
R	BURNER LENGTH	0.00	
S	CENTER OF TOP DRUM TO TOP OF STEAM OUTLET	16.50	419
T	CENTER OF STEAM OUTLET TO FRONT	59.22	1504
U	FEEDWATER INLET, COUPLING (NPT)	1.50	38
V	FEEDWATER ELEVATION FROM BOTTOM	57.81	1468
W	OVERALL BOILER LENGTH	164.22	4171
X	OVERALL BOILER LENGTH WITH BURNER	0.00	
Y	OVERALL BOILER HEIGHT	104.31	2650

NOTE: DIMENSIONS SUBJECT TO CHANGE WITHOUT NOTICE. CONSULT FACTORY FOR CERTIFIED DIMENSIONS.

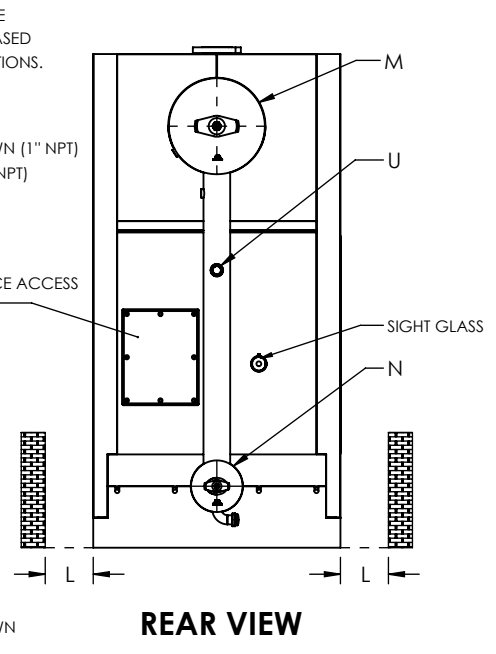
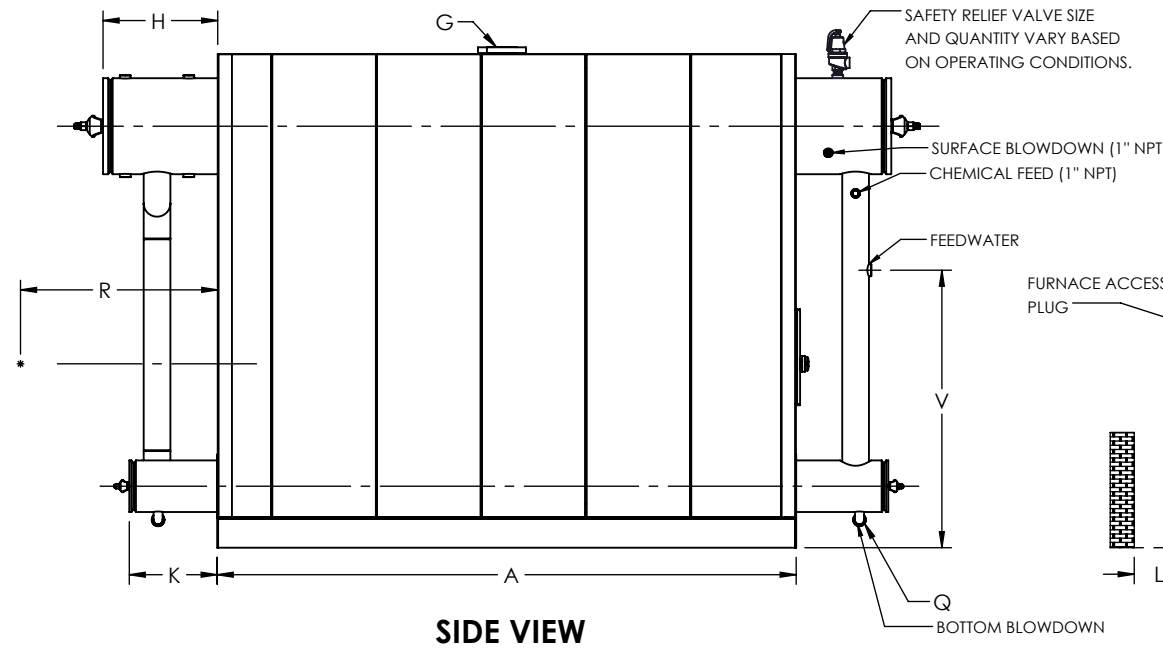
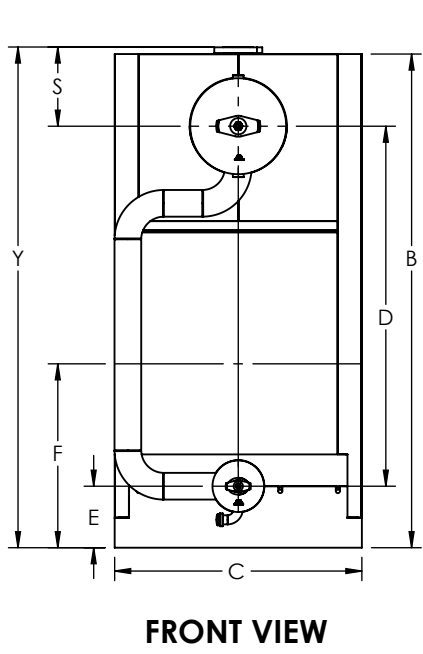

UNILUX ADVANCED MFG., LLC.
 30 COMMERCE PARK DRIVE
 NISKAYUNA, NY 12309
 Ph: (518) 344-7490

THIS DRAWING EMBODIES A CONFIDENTIAL PROPRIETARY DESIGN. ALL RIGHTS FOR REPRODUCTION, MANUFACTURING OR PATENTS ARE RESERVED BY UNILUX ADVANCED MANUFACTURING, LLC.

Drawn By: -	Date: -
Checked By: -	Date: -
Drawing No. : ZF 800HS-SUBMITTAL	
File No. : QBXXX	REV. : 00

PROJECT:	-
LOCATION:	-
MODEL:	ZF 800HS
BURNER:	-
ELECTRIC:	-
SUPPLY PSI:	-

ZONE	REV.	DESCRIPTION	DATE
REVISIONS			