

FLUE GAS OUTLET CONNECTION		
FLANGE DIMENSIONS	in	mm
O.D.	23.00	584
I.D.	18.25	464
B.C.D	20.50	521
HOLE DIAMETER	0.53	13
No. OF HOLES	8	

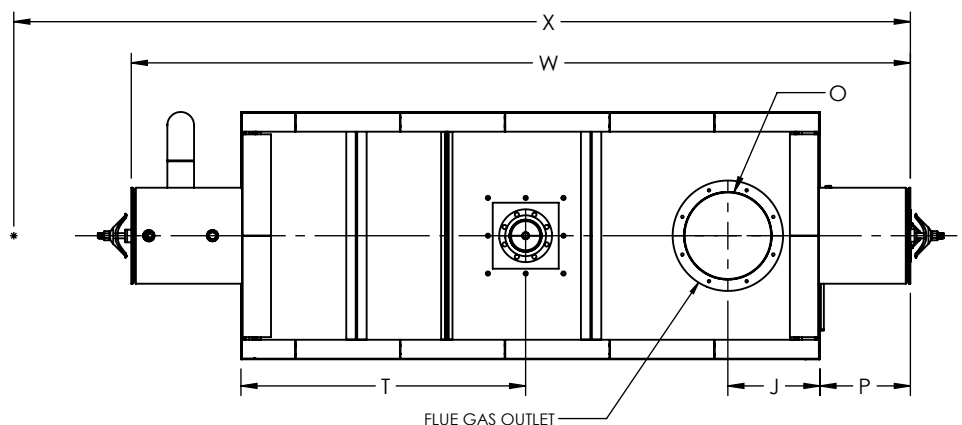

TOP VIEW

GENERAL DIMENSIONS		
	in	mm
A	BOILER BASE LENGTH	120.63 3064
B	BOILER HOUSING HEIGHT	102.85 2612
C	BOILER BASE WIDTH	51.50 1308
D	CENTER OF BOTTOM DRUM TO CENTER OF TOP DRUM	75.00 1905
E	CENTER OF BOTTOM DRUM TO BOTTOM	12.81 325
F	CENTER OF BURNER OPENING TO BOTTOM	38.31 973
G	STEAM OUTLET, FLANGE, CLASS 150 (NPS)	6.00 152
H	TOP DRUM CLEARANCE FROM FRONT	22.96 583
J	CENTER OF FLUE GAS OUTLET TO REAR	19.08 485
K	BOTTOM DRUM CLEARANCE FROM FRONT	18.13 460
L	TUBE REMOVAL CLEARANCE FROM BASE	35.00 889
M	UPPER DRUM, O.D.	20.00 508
N	LOWER DRUM, O.D.	10.75 273
O	FLUE GAS OUTLET, I.D.	18.00 457
P	TOP DRUM CLEARANCE FROM REAR	18.95 481
Q	BOTTOM BLOWDOWN (NPT)	1.50 38
R	BURNER LENGTH	0.00
S	CENTER OF TOP DRUM TO TOP OF STEAM OUTLET	16.50 419
T	CENTER OF STEAM OUTLET TO FRONT	59.19 1504
U	FEEDWATER INLET, COUPLING (NPT)	1.50 38
V	FEEDWATER ELEVATION FROM BOTTOM	57.81 1468
W	OVERALL BOILER LENGTH	162.31 4123
X	OVERALL BOILER LENGTH WITH BURNER	0.00
Y	OVERALL BOILER HEIGHT	104.31 2650

NOTE: DIMENSIONS SUBJECT TO CHANGE WITHOUT NOTICE. CONSULT FACTORY FOR CERTIFIED DIMENSIONS.

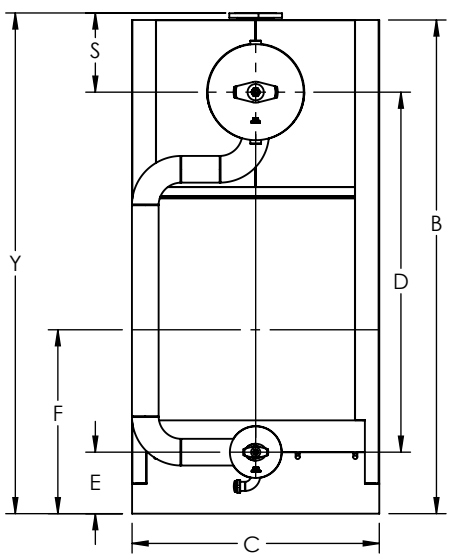

FRONT VIEW

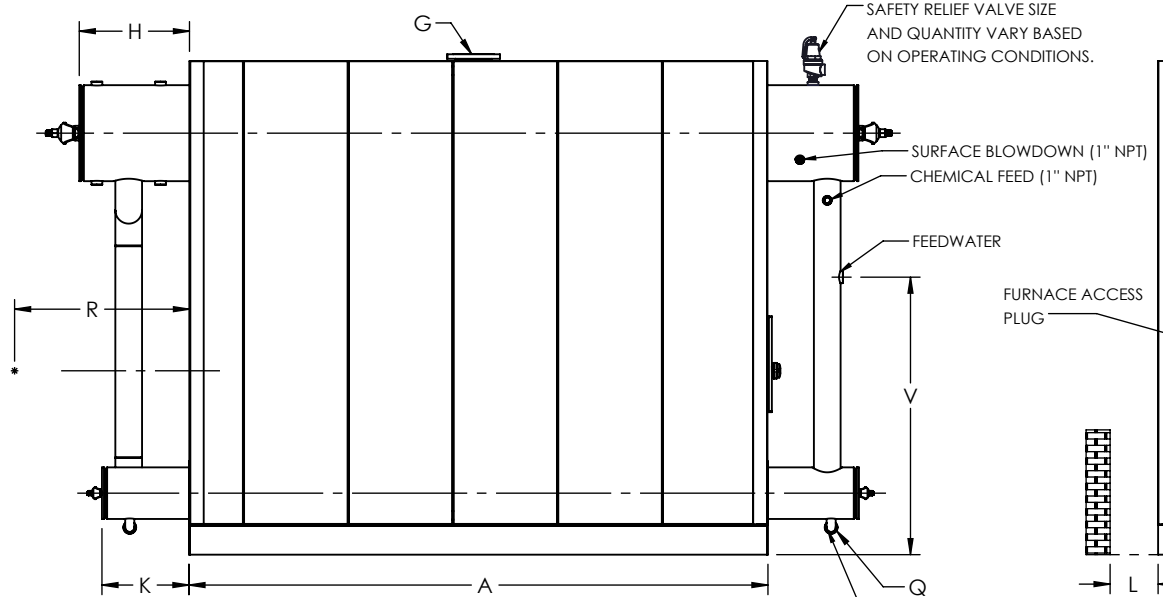

SIDE VIEW

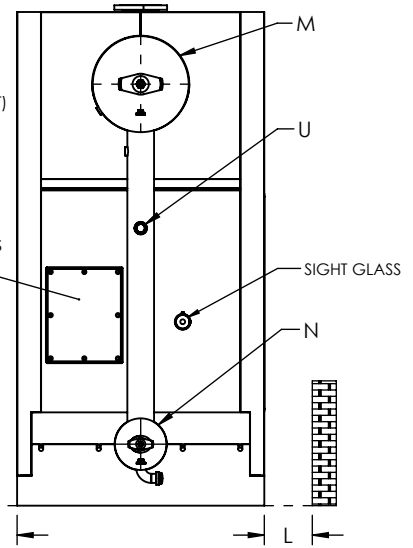

REAR VIEW

UNILUX ADVANCED MFG., LLC.
 30 COMMERCE PARK DRIVE
 NISKAYUNA, NY 12309
 Ph: (518) 344-7490



THIS DRAWING EMBODIES A CONFIDENTIAL PROPRIETARY DESIGN. ALL RIGHTS FOR REPRODUCTION, MANUFACTURING OR PATENTS ARE RESERVED BY UNILUX ADVANCED MANUFACTURING, LLC.

Drawn By:	-	Date:	-
Checked By:	-	Date:	-
Drawing No.:	ZF 800LS-SUBMITTAL		
File No.:	QBXXX	REV.:	00

PROJECT:	-
LOCATION:	-
MODEL:	ZF 800LS
BURNER:	-
ELECTRIC:	-
SUPPLY PSI:	-

ZONE	REV.	DESCRIPTION	DATE
		REVISIONS	